

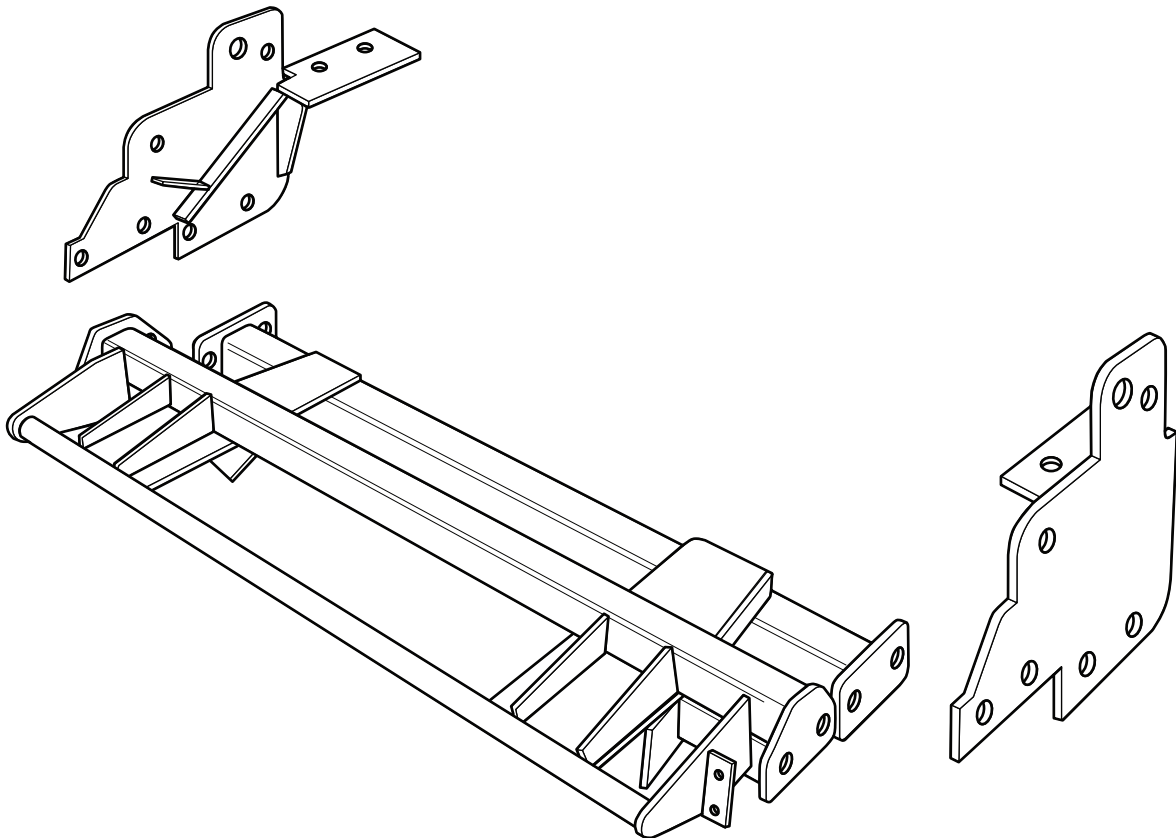

SNO-PRO[®] 3000

**2008 - Sterling Bullet / Dodge 4500, 5500
9' - 10' (With Snow Plow Prep. ONLY)**

Vehicle Mounting Kit: 1HD8



Curtis Industries Inc. LLC, 111 Higgins St., Worcester, MA 01606 TEL: (800) 343-7676 FAX: (508) 854-3377 For Parts and information visit us at www.Curtisindustries.net
Curtis Industries Inc. LLC, reserves the right to change product design or specifications without notice or liability.
Curtis Snow Plows are protected by the following U.S. Patent Numbers: 6,145,222 and 6,209,231 Licensed under U.S. Patent Number 5,568,694 & Canadian Patent Number 2,137,853.
Other patents pending.

1HD8 Vehicle Mount Kit Parts List

Item #	Description	Qty.
1	Mounting Frame	1
2	Driver's Side Push Arm	1
3	Passenger's Side Push Arm	1
Hardware Bag Components Included In This Kit		
4	5/8"-18 x 2" Hex Head Bolt Plated	4
5	5/8" Lock Washer, Plated	4
6	5/8" Flat Washer, Plated	4
7	5/8"-18 Hex Nuts, Plated	4
8	7/8" Hex Head Bolt, Plated	2
9	7/8" Lock Washer, Plated	2
10	7/8" Flat Washer, Plated	2
11	7/8" Hex Nuts, Plated	2
12	M10 x 1.5 x 60mm Hex Head Bolt, Plated	4
13	10mm Flat Washer, Plated	4
14	10mm Lock Washer, Plated	4
Hardware Components Included In Plow Light Harness Kit		
1a	Dual Plug Harness Bracket	1
-	10-32 x 3/4" Hex Head Screw, Plated	2
-	10-32 Nylock Lock Nut, Plated	2
-	8-32 x 1" Hex Head Screw, Plated	1
-	8-32 Nylock Lock Nut, Plated	1
-	#8 Nylon Flat Washer, 3/4" O.D.	1
-	#8 Flat Washer, SAE, Plated	1



WARNING

It is highly recommended that front "helper springs", "airshocks", or other similar devices be installed onto this vehicle to prevent the front suspension from "bottoming out" while carrying a snow plow.

Vehicle must be properly "ballasted" by placing ballast weight behind the centerline of Rear Axle so that no more than 62% of the total weight of the Vehicle, Snow Plow, Driver, Ballast weight, (and any cargo) is placed on the Front Axle while at the same time not exceeding the Gross Vehicle Weight Rating and Front or Rear Gross Axle Weight Ratings.

1HD8 Mounting

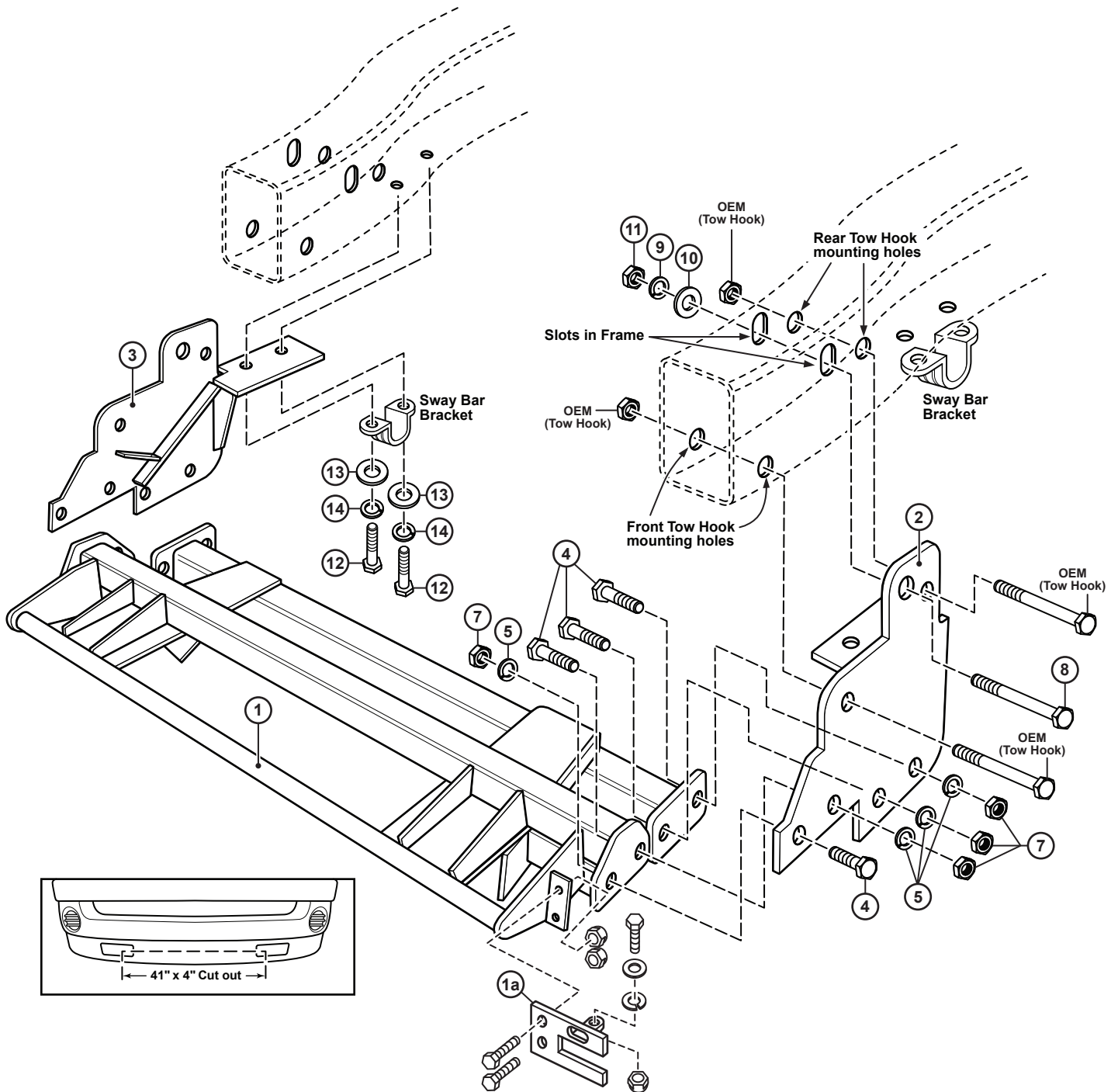

Curtis Industries, LLC. reserves the right to change product design or specifications without notice or liability. Curtis Snow Plows and Truck equipment should only be used on vehicles equipped with the manufacturer's Snow Plow preparation package. Snow Plowing without the original snow plow preparation package may damage your vehicle and the added weight of the equipment may impair the operation and control of the vehicle.

1HD8: 2008 - Sterling Bullet / Dodge 4500, 5500

Mounting Kit Installation Instructions

1. VEHICLE PREPARATION

- (1a.) Remove the vehicle front Tow Hooks and save all hardware for later installation.
- (1b.) Remove the four M10 bolts holding the sway bar bracket in place and save.
- (1c.) Cut a section 41" x 4" out of the center of the front air dam.



NOTE

All fasteners should remain loose or "finger tight" until all components have been attached to vehicle or installation instructions specify tightening.

IMPORTANT

We strongly recommend using removable thread locking adhesive on all mounting fasteners in vehicles for heavy duty, commercial use.



NOTE

If the plow mounting frame (1) is ever removed from the vehicle, all the original equipment fasteners must be reinstalled before the vehicle is put back into service.

2. DRIVER'S SIDE PUSH ARM

- (2a.) Install the driver's side push arm (2) on the outside of the frame lining up the two holes in the push arm with the two holes where the tow hooks had been fastened. Fasten using the same bolts and nuts that fastened the Tow Hook.
- (2b.) Line up the large slot on outside of the frame with the bigger top hole on the push arm and insert the 7/8" hex head bolt (7), 7/8" flat washer (9) and 7/8" lock washer (8) and 7/8" hex nut (14).

3. PASSENGER'S SIDE PUSH ARM

- (3a.) Install the passenger's side push arm (3) in the same sequence and with the same amount and type of fasteners as the driver's side push arm (2).
- (3b.) Fasten the sway bar back by aligning the two holes on the rear horizontal plate of the push arm (2) with the two sway bar bracket holes on bottom of the frame. Insert original M10 bolts x 1.5 x 60mm hex head bolts through the bracket, through the push arm plate and into the threaded holes in the frame.

4. MOUNTING FRAME

- (4a.) Lift the mounting frame (1) up under the front of the vehicle with the end plates of the cross tubes between the push arms (2) & (3). Line up the holes in the end plates of the cross tubes with the holes in the push arms and attach using 5/8"-18 x 2" bolts (5), 5/8" lock washers (11), and 5/8"-18 hex nuts (13).
- (4b.) Fully tighten all original equipment and added mounting fasteners.

5. FINAL ADJUSTMENT AND INSPECTION

Inspect the mounting attachment bolts to be certain that they are all in place and that they are all tight.

6. OPTIONAL PLUG MOUNT BRACKET INSTALL



NOTE

Install the Plug Mount Bracket if the harness will be mounted on the frame kit, otherwise, the harness may be routed through the grill, bumper, etc.

Using (2) 10-32 x 3/4" hex bolts and nylon locknuts, fasten the Plug Mount Bracket to the Plug Mount Bracket Mounting Tab located on the drivers side of the frame kit receiver. The included 8-32 hardware is used for mounting the hi-amp battery leads to the Plug Mount Bracket, if used.

