

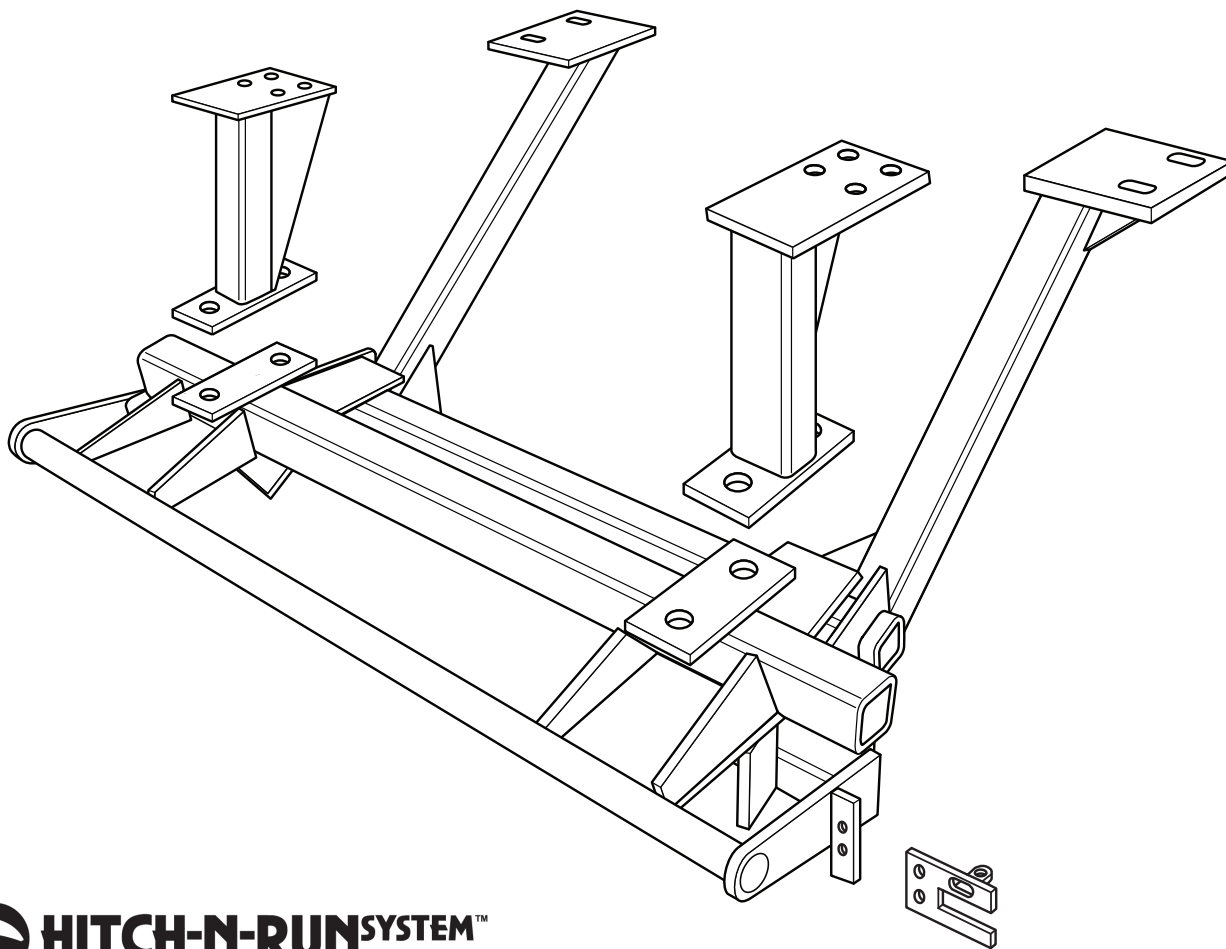

# SNO-PRO<sup>®</sup> 3000

**2005 - GM Topkick / Kodiak 4500, 5500 4x4  
(With Snow Plow Prep. Package ONLY)**

## Vehicle Mounting Kit: 1HD3



Curtis Industries Inc. LLC, 111 Higgins St., Worcester, MA 01606 TEL: (800) 343-7676 FAX: (508) 854-3377 For Parts and information visit us at [www.Curtisindustries.net](http://www.Curtisindustries.net)  
Curtis Industries Inc. LLC, reserves the right to change product design or specifications without notice or liability.  
Curtis Snow Plows are protected by the following U.S. Patent Numbers: 6,145,222 and 6,209,231 Licensed under U.S. Patent Number 5,568,694 & Canadian Patent Number 2,137,853.  
Other patents pending.

## 1HD3 Vehicle Mount Kit Parts List

Item #	Description	Qty.
1	Mounting Frame	1
2	Passenger's Side Front Hanger	1
3	Driver's Side Front Hanger	1
<b>Hardware Bag Components Included In This Kit</b>		
4	12mm x 1.75mm x 60mm Hex Head Bolt, Gr. 10.9, Plated	4
5	12mm x 1.75mm x 50mm Hex Head Bolt, Gr. 10.9, Plated	8
6	12mm Flat Washer, Plated	20
7	12mm Lock Washer, High Strength, Plated	4
8	12mm x 1.75mm Lock Nut, Gr. 10.9, Plated	8
9	5/8"-11 x 1-1/2" Hex Head Bolt, Gr. 8, Plated	4
10	5/8"-11 Hex Nut , Gr. 8, Plated	4
11	5/8" Lock Washer, High Strength, Plated	4
<b>Hardware Components Included In Plow Light Harness Kit</b>		
1a	Dual Plug Harness Bracket	1
-	10-32 x 3/4" Hex Head Screw, Plated	2
-	10-32 Nylock Lock Nut, Plated	2
-	8-32 x 1" Hex Head Screw, Plated	1
-	8-32 Nylock Lock Nut, Plated	1
-	#8 Nylon Flat Washer, 3/4" O.D.	1
-	#8 Flat Washer, SAE, Plated	1



### WARNING

It is highly recommended that front "helper springs", "airshocks", or other similar devices be installed onto this vehicle to prevent the front suspension from "bottoming out" while carrying a snow plow.

Vehicle must be properly "ballasted" by placing ballast weight behind the centerline of Rear Axle so that no more than 62% of the total weight of the Vehicle, Snow Plow, Driver, Ballast weight, (and any cargo) is placed on the Front Axle while at the same time not exceeding the Gross Vehicle Weight Rating and Front or Rear Gross Axle Weight Ratings.

## 1HD3 Mounting

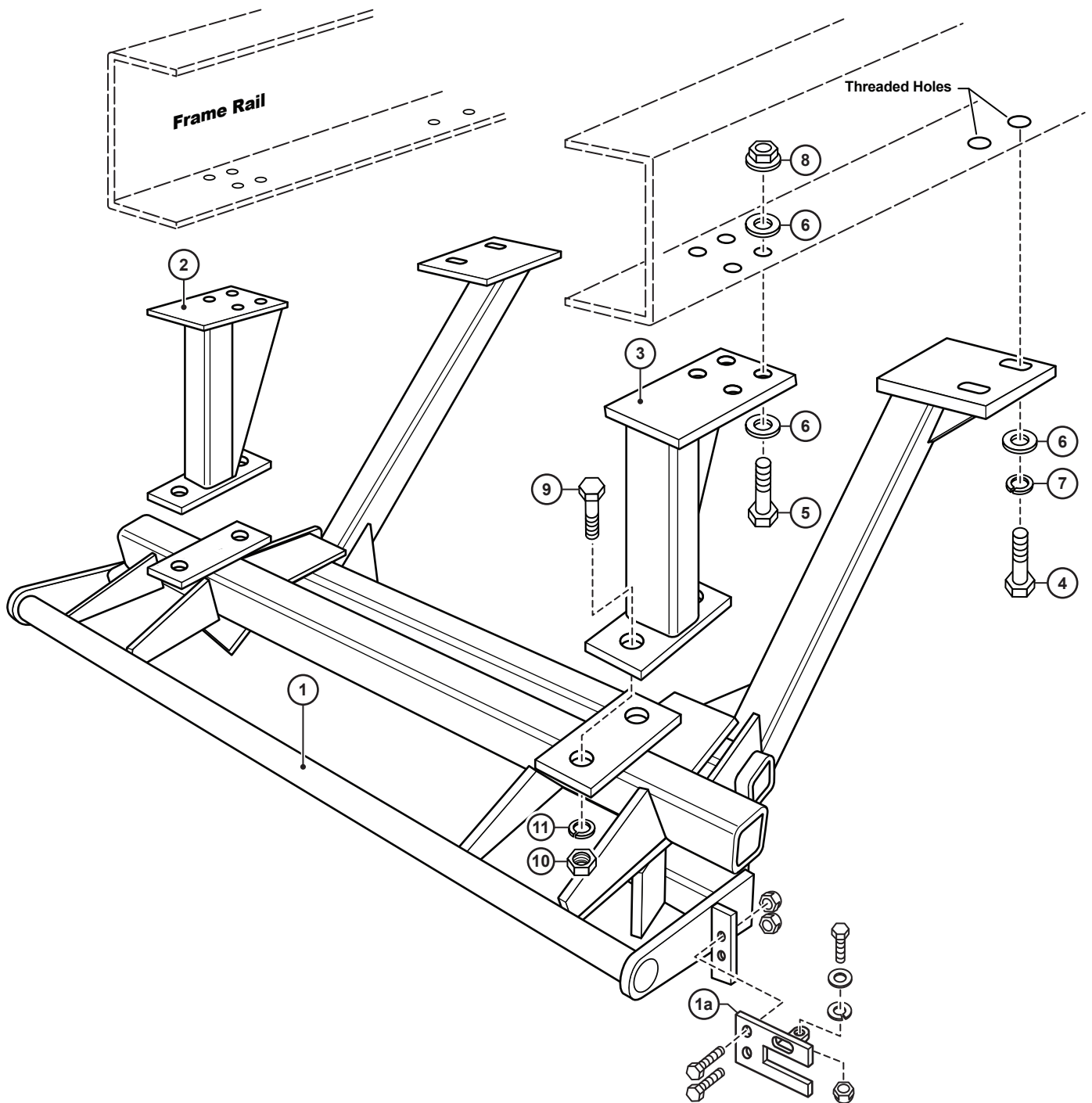

**Curtis Industries, LLC. reserves the right to change product design or specifications without notice or liability. Curtis Snow Plows and Truck equipment should only be used on vehicles equipped with the manufacturer's Snow Plow preparation package. Snow Plowing without the original snow plow preparation package may damage your vehicle and the added weight of the equipment may impair the operation and control of the vehicle.**

# 1HD3: 2005 - GM Topkick / Kodiak 4500, 5500 4x4

## Mounting Kit Installation Instructions

### 1. VEHICLE PREPARATION

- (1a.) Remove and store the eight vertical original equipment bolts and nuts that attach the front cross member to the driver's and passenger's side frame rail just behind the front bumper.
- (1b.) Remove and store the four vertical original equipment bolts that attach the rear cast steel motor mounts to the frame rails. Save all the original equipment parts and fasteners for possible reinstallation if the plow mounting is removed.



#### NOTE

All fasteners should remain loose or "finger tight" until all components have been attached to vehicle or installation instructions specify tightening.

#### IMPORTANT

We strongly recommend using removable thread locking adhesive on all mounting fasteners in vehicles for heavy duty, commercial use.



#### NOTE

If the plow mounting frame (1) is ever removed from the vehicle, all the original equipment fasteners must be reinstalled before the vehicle is put back into service.

### 2. FRONT HANGERS

- (2a.) Place the driver's side front hanger (3) onto the bottom surface of the driver's side frame rail just behind the front bumper with the four holes of the top plate lined up with the holes that bolts and nuts were removed from previously. Fasten loosely to the frame rail and front cross member using four 12mm x 1.75mm x 50mm bolts (5), eight 12mm flat washers (6), and four 12mm x 1.75mm lock nuts (8).
- (2b.) Install and loosely fasten the passenger's side front hanger (2) in the same sequence and with the same number and type of fasteners.

### 3. MOUNTING FRAME

- (3a.) Lift the mounting frame (1) up between the frame rails under the front of the vehicle with the two holes in each front bolting bracket lined up with the holes in the bottom plate of each of the front hangers (2), (3). Fasten loosely using four 5/8"-11 x 1-1/2" bolts (9), four 5/8" lock washers (11), and four 5/8"-11 nuts (10).
- (3b.) Line up the holes in each rear frame plate of the mounting frame (1) with the two threaded holes in each frame rail at the cast steel rear motor mounts. Fasten the rear frame plates using four 12mm x 1.75mm x 60mm bolts (4), four 12mm flat washers (7), and four 12mm lock washers. Tighten all fasteners fully starting with the 12mm-1.75mm bolts (4), (5) and nuts (8).

### 4. FINAL ADJUSTMENT AND INSPECTION

Inspect the mounting attachment bolts to be certain that they are all in place and that they are all tight.

### 5. OPTIONAL PLUG MOUNT BRACKET INSTALL



#### NOTE

Install the Plug Mount Bracket if the harness will be mounted on the frame kit, otherwise, the harness may be routed through the grill, bumper, etc.

Using (2) 10-32 x 3/4" hex bolts and nylon locknuts, fasten the Plug Mount Bracket to the Plug Mount Bracket Mounting Tab located on the drivers side of the frame kit receiver. The included 8-32 hardware is used for mounting the hi-amp battery leads to the Plug Mount Bracket, if used.

