

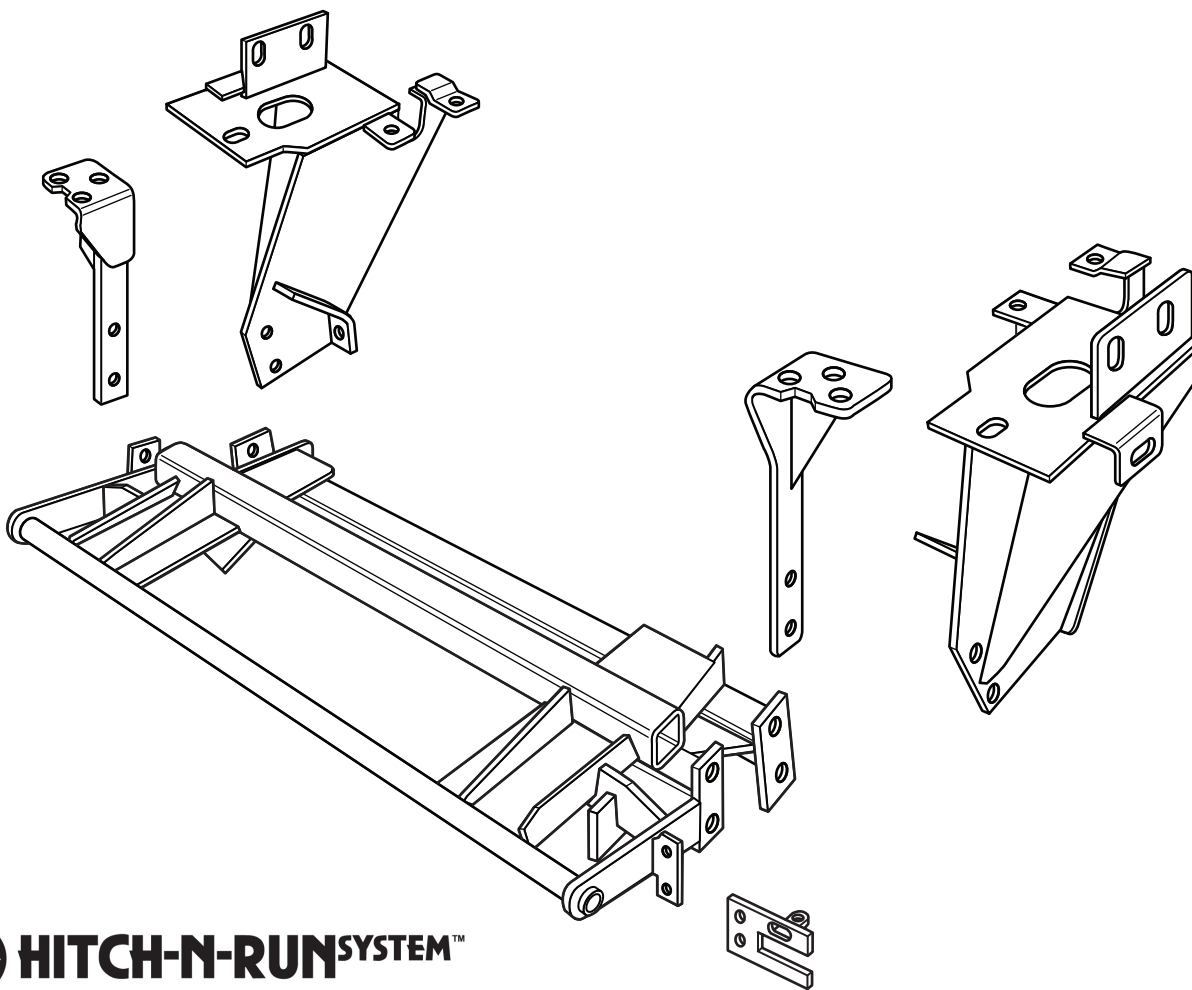

SNO-PRO[®] 3000

**2005 - 2008 Ford Super Duty F-450, F-550
Sno-Pro 'C' • 9'-10' (With Snow Prep. Package ONLY)**

Vehicle Mounting Kit: 1HD1



Curtis Industries Inc. LLC, 111 Higgins St., Worcester, MA 01606 TEL: (800) 343-7676 FAX: (508) 854-3377 For Parts and information visit us at www.Curtisindustries.net
Curtis Industries Inc. LLC, reserves the right to change product design or specifications without notice or liability.
Curtis Snow Plows are protected by the following U.S. Patent Numbers: 6,145,222 and 6,209,231 Licensed under U.S. Patent Number 5,568,694 & Canadian Patent Number 2,137,853.
Other patents pending.

1HD1 Vehicle Mount Kit Parts List

Item #	Description	Qty.
1	Mounting Frame	1
2	Driver's Side Push Arm	1
3	Passenger's Side Push Arm	1
4	Driver's Side Front Hanger	1
5	Passenger's Side Front Hanger	1
Hardware Bag Components Included In This Kit		
6	M10 x 1.5 x 40 Bolt, Gr.10.9, Plated	4
7	M10 Lock Washer, High Strength, Plated	4
8	M10 Flat Washer, Plated	4
10	1/2"-20 x 1-1/2" Bolt, Gr. 8, Plated	8
11	1/2"-20 x 2" Bolt, Gr. 8, Plated	4
12	1/2" Lock Washer, High Strength, Plated	12
13	1/2"-20 Hex Nut, Gr. 8, Plated	12
14	5/8"-11 x 2-1/2" Carriage Bolt, Gr. 8, Plated	2
15	5/8" Lock Washer, High Strength, Plated	2
16	5/8"-11 Hex Jam Nut, Gr. 8, Plated	4
Hardware Components Included In Plow Light Harness Kit		
1a	Dual Plug Harness Bracket	1
-	10-32 x 3/4" Hex Head Screw, Plated	2
-	10-32 Nylock Lock Nut, Plated	2
-	8-32 x 1" Hex Head Screw, Plated	1
-	8-32 Nylock Lock Nut, Plated	1
-	#8 Nylon Flat Washer, 3/4" O.D.	1
-	#8 Flat Washer, SAE, Plated	1



WARNING

It is highly recommended that front "helper springs", "airshocks", or other similar devices be installed onto this vehicle to prevent the front suspension from "bottoming out" while carrying a snow plow.

Vehicle must be properly "ballasted" by placing ballast weight behind the centerline of Rear Axle so that no more than 62% of the total weight of the Vehicle, Snow Plow, Driver, Ballast weight, (and any cargo) is placed on the Front Axle while at the same time not exceeding the Gross Vehicle Weight Rating and Front or Rear Gross Axle Weight Ratings.

1HD1 Mounting

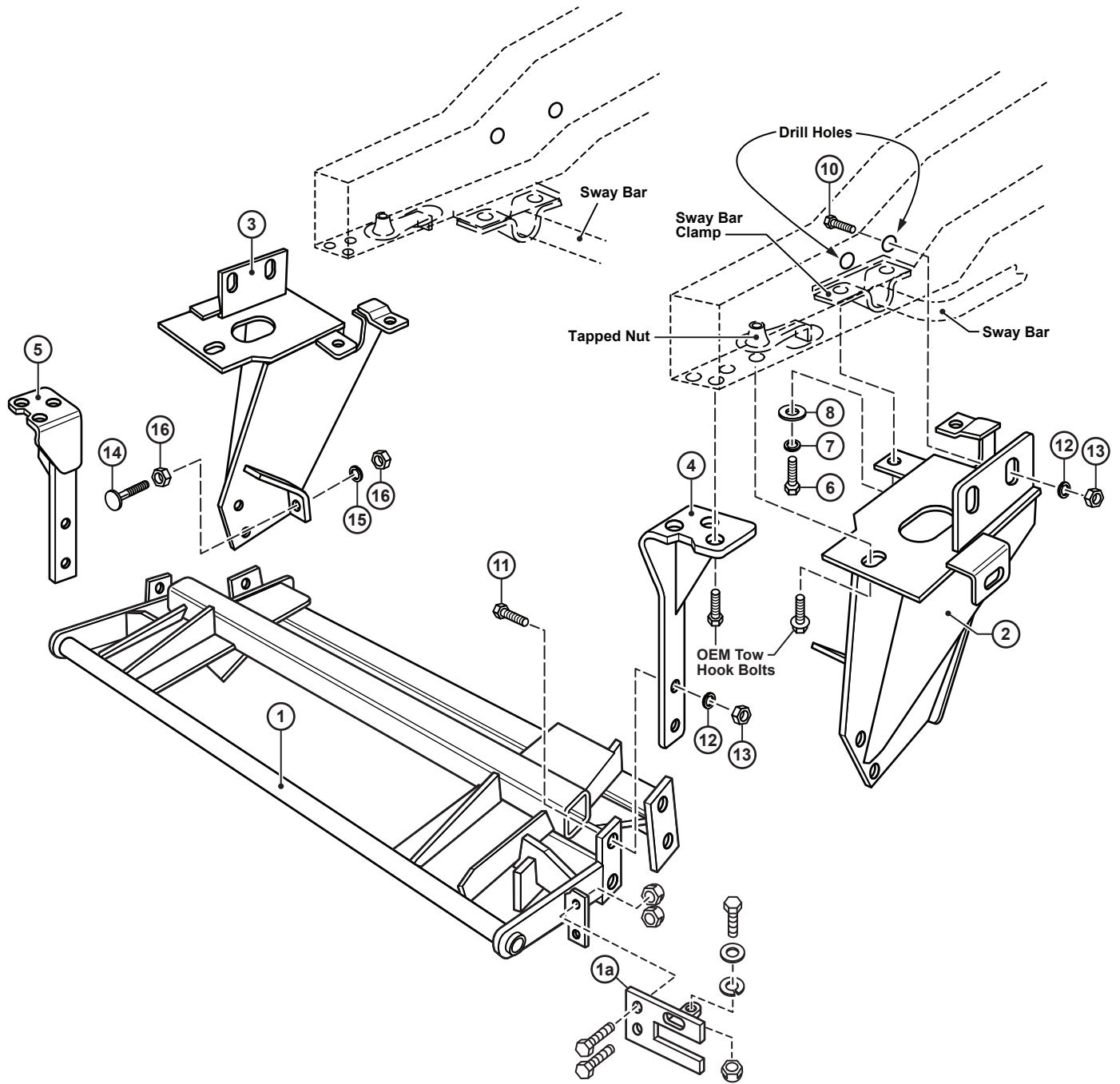

Curtis Industries, LLC. reserves the right to change product design or specifications without notice or liability. Curtis Snow Plows and Truck equipment should only be used on vehicles equipped with the manufacturer's Snow Plow preparation package. Snow Plowing without the original snow plow preparation package may damage your vehicle and the added weight of the equipment may impair the operation and control of the vehicle.

1HD1: 2005 - 2008 Ford Super Duty F-450, F-550

Mounting Kit Installation Instructions

1. VEHICLE PREPARATION

- (1a.) Temporarily remove the vehicle front bumper, "Blocker Beam" and Tow Hooks. Save all fasteners for reuse. The bumper and Tow Hooks will be reinstalled with plow mount. The "Blocker Beam" will not be reinstalled. Save and store the "Blocker Beam" so that it can be reinstalled if the mounting frame is removed from the vehicle.
- (1b.) Screw a 5/8"-18 hex jam nut (16) all the way onto each of the 5/8"-18 x 2-1/2" carriage bolts (14). Place each carriage bolt / jam nut assembly through the ears on the driver's side and passenger's side push arms (2) & (3) with the heads of the carriage bolts toward the front of the vehicle. Fasten loosely using a 5/8" lockwasher (15) and 5/8"-18 hex jam nut (16) on each carriage bolt / jam nut assembly.
- (1c.) Remove the two 10mm. "U" style tapped hole nuts from the "Blocker Beam" and install one into the vertical slotted hole on each push arm (2) & (3).
- (1d.) Cut out and remove a 30" section from the center of the plastic air dam under the vehicle front bumper.
- (1e.) Remove and discard the two 10mm. bolts holding the "U" shaped sway bar clamp bracket to each frame rail.



NOTE

All fasteners should remain loose or "finger tight" until all components have been attached to vehicle or installation instructions specify tightening.

IMPORTANT

We strongly recommend using removable thread locking adhesive on all mounting fasteners in vehicles for heavy duty, commercial use.



NOTE

If the plow mounting frame (1) is ever removed from the vehicle, all the original equipment fasteners must be reinstalled before the vehicle is put back into service.

2. FRONT HANGERS

Line up the three slotted holes in each front hanger (4) & (5) with the tow hook holes in the lower flange of each frame rail. Attach using the original equipment tow hook bolts up through the front hangers, through the holes in the lower flange of the frame rails, and threaded into the holes in the tow hooks.

3. MOUNTING FRAME

Lift the mounting frame (1) up under the front of the vehicle with the end plates of the front cross tube between the vertical bars of the front hangers (4) & (5). Line up the holes in the end plates of the cross tube with the holes in the vertical bars of the front hangers and attach using 1/2"-20 x 2" bolts (11), 1/2" lock washers (12), and 1/2"- 20 hex nuts (13).

4. DRIVER'S SIDE PUSH ARM

- (4a.) Place the horizontal plate on the upper end of the driver's side push arm (2) flat against the lower flange of the frame rail with the two rear bolting ears on top of the "U" shaped sway bar clamp bracket and the front hole lined up with the hole in the lower flange. Fasten to the lower flange using a M14 bolt previously removed from the "Blocker Beam" at the front hole, and two M10 x 1.5 x 40 bolts (6), M10 flat washers (8), and M10 lock washers (7) up through the bolting ears, through the "U" shaped sway bar clamp bracket,

through the frame bracket, and threaded into the existing vehicle "U" nuts.

- (4b.) Using the large oval hole in the horizontal plate of the push arm and lower flange of the frame rail for access, install a 1/2"-20 x 1-1/2" bolt (10) out through the outer flange of the frame rail and vertical plate of the push arm. Fasten using a 1/2" lock washer (12) and 1/2"-20 hex nut (13). Line up the two holes in the front end of the Driver's side push arm (2) with the holes in the end plate of the rear cross tube of the mounting frame (1). Fasten using 1/2"-20 x 1-1/2" bolts (10), 1/2" lock washers (12), and 1/2"-20 hex nuts (13).

5. PASSENGER'S SIDE PUSH ARM

Install the passenger's side push arm (3) in the same sequence and with the same amount and type of fasteners as the driver's side push arm (2).

6. DRILLING AND TIGHTENING

- (6a.) Tighten the tow hook bolts and all of the fasteners holding the push arms (2) & (3) to the frame rails. Tighten the 1/2" fasteners holding the front hangers (4) & (5) to the end plates of the front cross tube on the mounting frame (1). Tighten the 1/2" fasteners holding the front ends of the push arms (2) & (3) to the end plates of the rear cross tube on the mounting frame (1).
- (6b.) Using the rear hole in each vertical ear of the push arms (2) & (3) as guides, drill 1/2" dia. holes through the outer flange of each frame rail. Using the large oval hole in the horizontal plate of the push arms and lower flange of the frame rails for access, install 1/2"-20 x 1-1/2" bolt (10) out through the outer flange of the frame rails and vertical plate of the push arms. Fasten and tighten using 1/2" lock washers (12) and 1/2"-20 hex nuts (13). Adjust the 5/8"-18 x 2-1/2" carriage bolts (14) with the front 5/8" jam nuts (16) so that the heads of the carriage bolts are tight against the back of the rear cross tube of the mounting frame (1). Lock the 5/8"-18 x 2-1/2" carriage bolts (14) in place using the rear 5/8"-18 jam nuts (16).
- (6c.) Reinstall the vehicle front bumper using the original equipment fasteners. Attach the bumper braces to the previously installed "U" style tapped nuts in the push arms (2) & (3) using the original equipment bolts.

7. FINAL ADJUSTMENT AND INSPECTION

Inspect all Mounting Frame Attachment Bolts to be certain that all six Bolts are in position and fully tightened.

8. OPTIONAL PLUG MOUNT BRACKET INSTALL



NOTE

Install the Plug Mount Bracket if the harness will be mounted on the frame kit, otherwise, the harness may be routed through the grill, bumper, etc.

Using (2) 10-32 x 3/4" hex bolts and nylon locknuts, fasten the Plug Mount Bracket to the Plug Mount Bracket Mounting Tab located on the drivers side of the frame kit receiver. The included 8-32 hardware is used for mounting the hi-amp battery leads to the Plug Mount Bracket, if used.

