

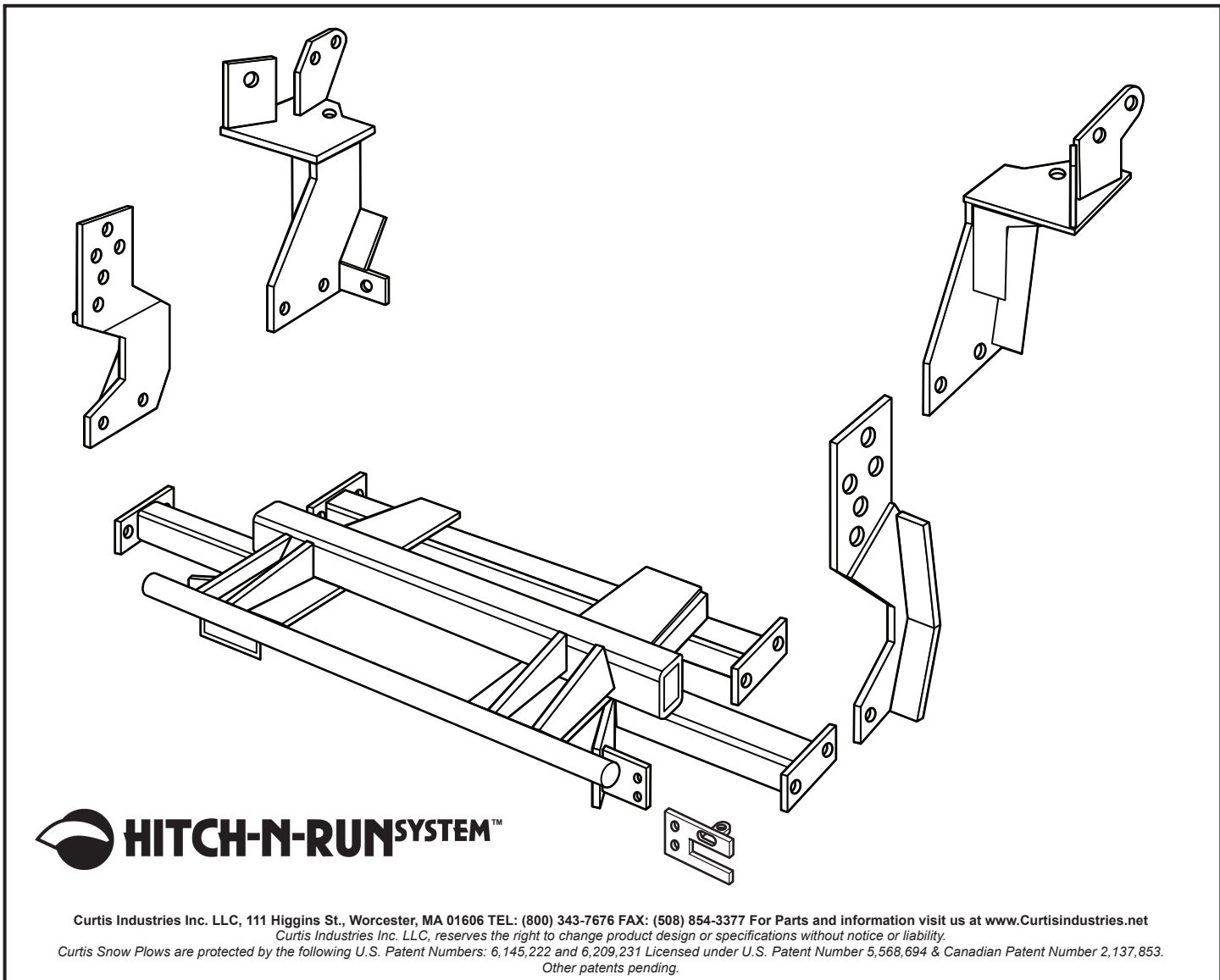

SNO-PRO[®] 3000

**1981 - 1991 Ford F-250, F-350
(With Snow Plow Prep. Package ONLY)**

Vehicle Mounting Kit: 1FK8



1FK8 Vehicle Mount Kit Parts List

Item #	Description	Qty.
1	Driver's Side Front Hanger	1
2	Passenger's Side Front Hanger	1
3	Mounting Frame	1
4	Driver's Side Push Arm	1
5	Passenger's Side Push Arm	4
10	5/8"-11 x 1-1/2" Strap Bolt (12" Long)	2
15	3/4"-10 x 2" Special Toggle Bolt	2
Hardware Bag Components Included In This Kit		
6	1/2" - 13 x 1-1/2" Bolt, Gr. 5, Cad., Plated	8
7	1/2" Lockwasher, Cad., Plated	8
8	1/2" -13 Hex Nut, Cad., Plated	8
9	5/8"-11 x 1-1/2" Bolt, Gr. 5, Cad., Plated	6
11	5/8"-11 x 2-1/2" Carriage Bolt, Gr. 5, Cad., Plated	2
12	5/8" Lockwasher, Cad., Plated	10
13	5/8"-11 Hex Jam Nut, Cad., Plated	4
14	5/8"-11 Hex Nut, Cad., Plated	8
16	3/4" Lockwasher , Cad., Plated	2
17	3/4"-10 Hex Nut, Cad., Plated	2
Hardware Components Included In Plow Light Harness Kit		
3a	Plug Mount Bracket	1
-	10-32 x 3/4" Hex Head Screw, Plated	2
-	10-32 Nylock Lock Nut, Plated	2
-	8-32 x 1" Hex Head Screw, Plated	1
-	8-32 Nylock Lock Nut, Plated	1
-	#8 Nylon Flat Washer, 3/4" O.D.	1
-	#8 Flat Washer, SAE, Plated	1



WARNING

It is highly recommended that front "helper springs", "airshocks", or other similar devices be installed onto this vehicle to prevent the front suspension from "bottoming out" while carrying a snow plow.

Vehicle must be properly "ballasted" by placing ballast weight behind the centerline of Rear Axle so that no more than 62% of the total weight of the Vehicle, Snow Plow, Driver, Ballast weight, (and any cargo) is placed on the Front Axle while at the same time not exceeding the Gross Vehicle Weight Rating and Front or Rear Gross Axle Weight Ratings.

1FK8 Mounting

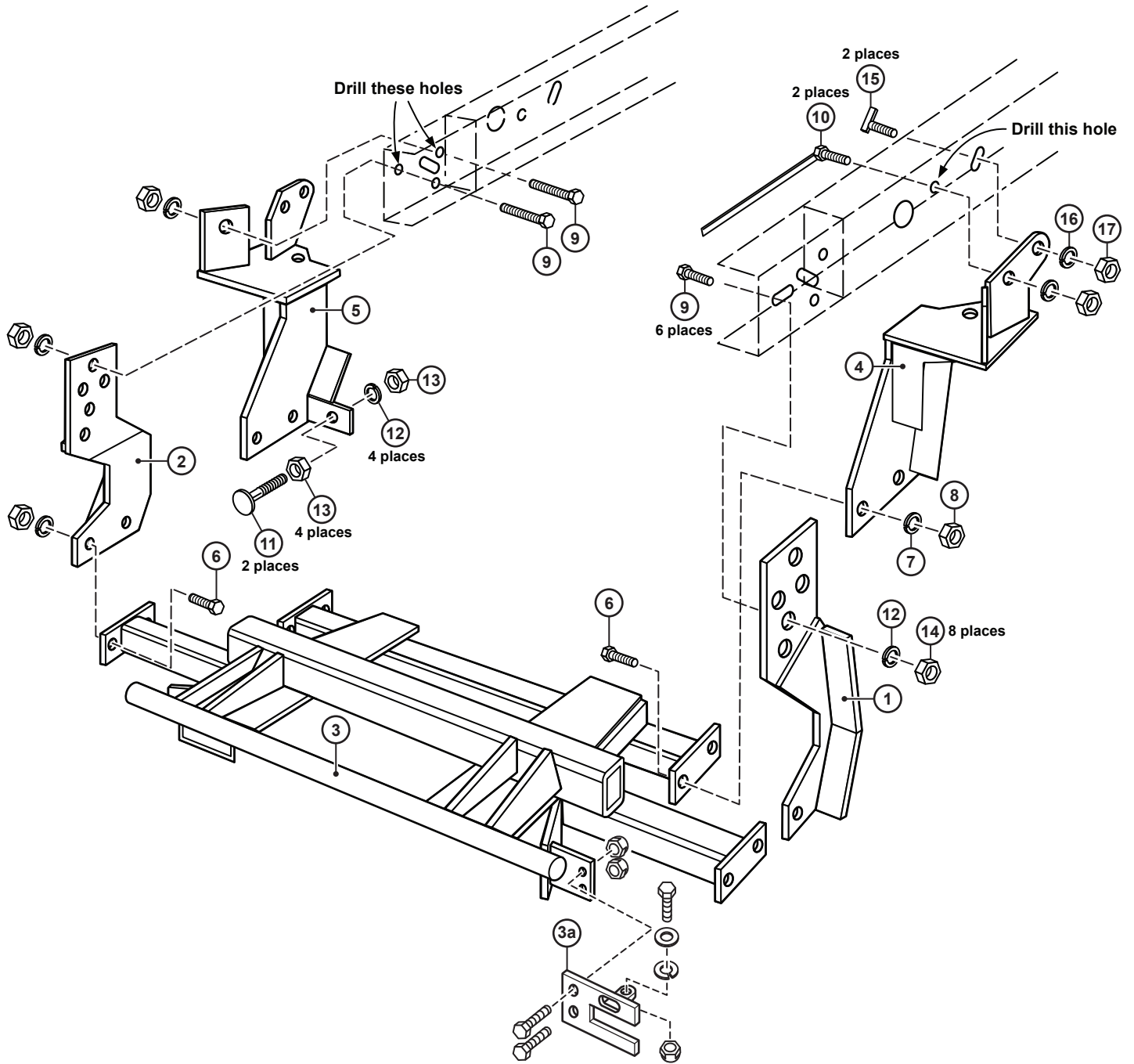

Curtis Industries, LLC. reserves the right to change product design or specifications without notice or liability. Curtis Snow Plows and Truck equipment should only be used on vehicles equipped with the manufacturer's Snow Plow preparation package. Snow Plowing without the original snow plow preparation package may damage your vehicle and the added weight of the equipment may impair the operation and control of the vehicle.

1FK8: 1981 - 1991 Ford F-250, F-350

Mounting Kit Installation Instructions

1. VEHICLE PREPARATION

- (1a.) Temporarily remove the vehicle front bumper by unbolting the bumper brackets from the frame rails. (If the vehicle does not have bumper brackets, unbolt the bumper from the frame rails.) Save all bumper or bumper bracket fasteners for reuse.
- (1b.) If the vehicle is equipped with an air dam, either remove it completely or cut and remove a 28" long section out of the center of it.
- (1c.) Screw a 5/8"-11 hex jam nut (13) all the way onto each of the 5/8"-11 x 2-1/2" carriage bolts (11). Place each carriage bolt / jam nut assembly through the ears on the driver's side and passenger's side push arms (4) & (5) with the heads of the carriage bolts toward the front of the vehicle. Fasten loosely using a 5/8" lockwasher (12) and 5/8"-11 hex jam nut (13) on each carriage bolt / jam nut assembly.



NOTE

All fasteners should remain loose or "finger tight" until all components have been attached to vehicle or installation instructions specify tightening.

- (1d.) Jack vehicle up from under the frame rails until front wheels clear the ground. Place jack stands under the frame rails to the rear of the front wheels to prevent unintended lowering of the vehicle.
- (1e.) From between the frame rails, place the upper end of the driver's side and passenger's side push arms (4) & (5) out through the space between the front springs and the lower flange of the frame rails.

On some vehicles, there may be a fuel return evaporative canister on the passenger's side frame rail that interferes with installing the passenger's side push arm (5). This canister and its bracket may have to be relocated up higher on the frame rail to permit installation of the push arm.



NOTE

- (1f.) Remove the jack stands from under the frame rails and lower the vehicle to the ground.

2. FRONT HANGERS

Line up the lower 11/16" dia. hole in the upper plate of each front hanger (1) & (2) with the front slotted hole in the outside flange of each frame rail. Attach each hanger to its respective frame rail using a 5/8"-11 x 1-1/2" bolt (9), 5/8" lockwasher (12), and 5/8"-11 nut (14). A 5/8" dia. hole will have to be drilled through the outside flange of each frame rail at a later step in the installation.

3. MOUNTING FRAME

Lift the Mounting frame (3) up under the front of the vehicle with the end plates of the front cross tube between the vertical bars of the front hangers (1) & (2). Line up the holes in the end plates of the cross tube with the holes in the vertical bars of the front hangers and attach using 1/2"-13 x 1-1/2" bolts (6), 1/2" lockwashers (7), and 1/2"-13 hex nuts (8).

4. DRIVER'S SIDE PUSH ARM

- (4a.) Insert the head of a 3/4"-10 x 2" special toggle bolt (15) into the large slotted hole located near the rear steering box bolt. Rotate the head of the bolt (15) so that the toggle "locks" into the slotted hole and will not turn. Place the rear most hole in the frame plate end of the driver's side push arm (4) on over the 3/4"-10 x 2" special toggle bolt (15) installed in the frame rail. Fasten using a 3/4" lockwasher (16), and 3/4"-10 hex nut (17).

- (4b.) Line up the two holes in the front end of the Driver's side push arm (4) with the holes in the end plate of the rear cross tube of the mounting frame (3). Fasten using 1/2"-13 x 1-1/2" bolts (6), 1/2" lockwashers (7), and 1/2"-13 nuts (8). Two 5/8" holes will have to be drilled in the outside flange of the frame rail at a later step in the installation.

5. PASSENGER'S SIDE PUSH ARM

Install the passenger's side push arm (5) in the same sequence and with the same amount and type of fasteners as the driver's side push arm (4).

6. DRILLING & TIGHTENING

- (6a.) Tighten the 5/8" fasteners holding the front hangers (1) & (2) to the frame rails. Tighten the 1/2" fasteners holding the mounting frame (3) to the front hangers (1) & (2). Hold the driver's side and passenger's side push arms (4) & (5) up tight the bottom flange of the frame rails and tighten the nuts on the 3/4"-10 x 2" special toggle bolts (15). Tighten the 1/2" fasteners holding the front ends of the push arms (4) & (5) to the end plates of the rear cross tube on the mounting frame (3).
- (6b.) Using the top hole in the upper plate of each front hanger (1) & (2) and the hole in each front frame plate on the push arms (4) & (5) as guides, drill 5/8" dia. holes through the outside flange of each frame rail. Fasten and tighten using 5/8"-11 x 1-1/2" bolts (9), 5/8" lockwashers (12), and 5/8"-11 nuts (14) in the drilled holes.
- (6c.) Using the remaining hole in each rear frame plate on the push arms (4) & (5) as a guide, drill a 5/8" dia. hole through the outside flange of each frame rail. Fasten and tighten using 5/8"-11 x 1-1/2" strap bolts (10), 5/8" lockwashers (12), and 5/8"-11 nuts (14) in the drilled holes.
- (6d.) Adjust the 5/8"-11 x 2-1/2" carriage bolts (11) with the front 5/8" jam nuts (13) so that the heads of the carriage bolts are tight against the back of the rear cross tube of the mounting frame (3). Lock the 5/8"-11 x 2-1/2" carriage bolts (11) in place using the rear 5/8"-11 jam nuts (13).

7. FINAL ADJUSTMENT AND INSPECTION

Reinstall the vehicle front bumper using the original equipment fasteners. Inspect the mounting attachment bolts to be certain that they are all in place and that they are all tight.

8. OPTIONAL PLUG MOUNT BRACKET INSTALL



NOTE

Install the Plug Mount Bracket if the harness will be mounted on the frame kit, otherwise, the harness may be routed through the grill, bumper, etc.

Using (2) 10-32 x 3/4" hex bolts and nylon locknuts, fasten the Plug Mount Bracket to the Plug Mount Bracket Mounting Tab located on the driver's side of the frame kit receiver. The included 8-32 hardware is used for mounting the hi-amp battery leads to the Plug Mount Bracket if used.

