

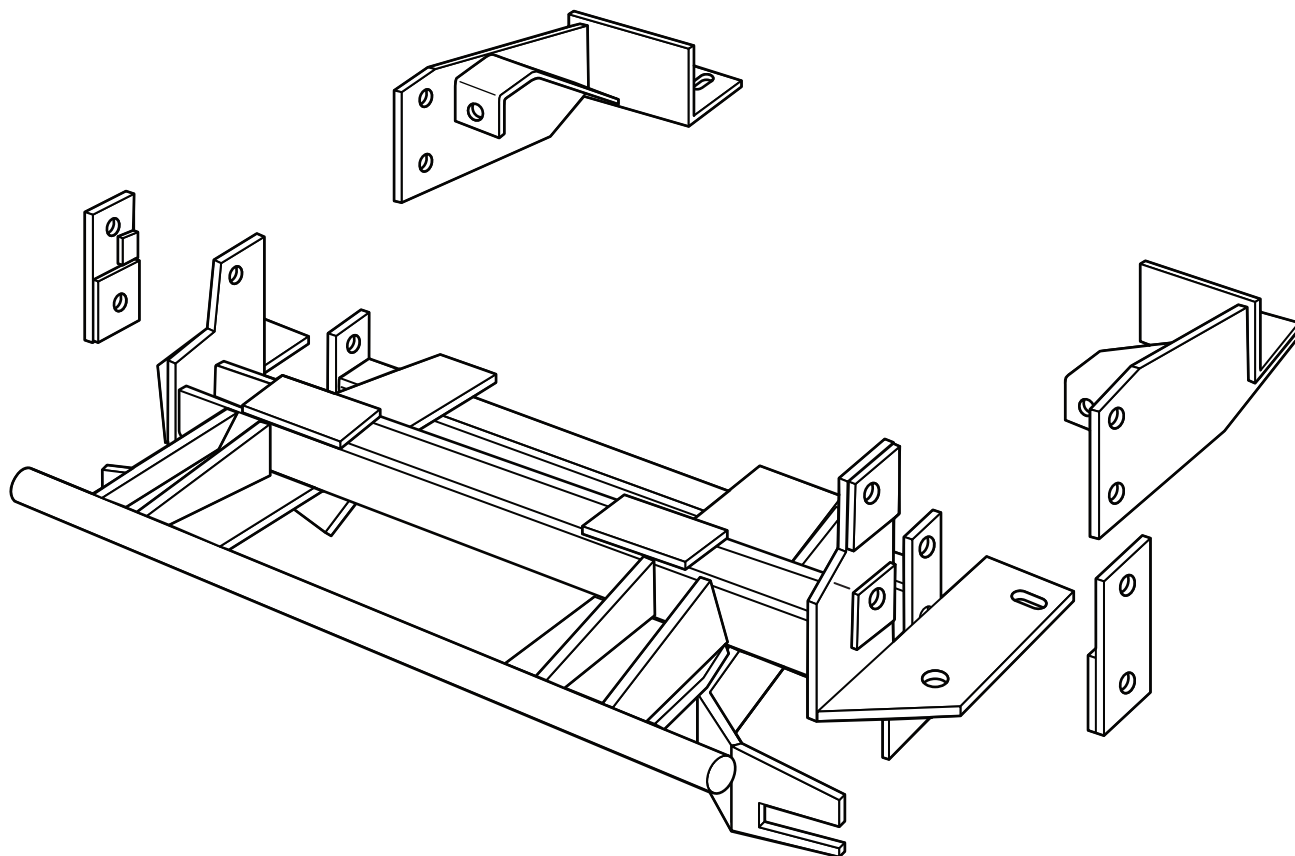

# SNO-PRO<sup>®</sup> 3000

**1999 - 2002 GM Silverado / Sierra K-2500 HD  
(4 x 4 With VYU ONLY)**

**Vehicle Mounting Kit: 1FK3B**



Curtis Industries Inc. LLC, 111 Higgins St., Worcester, MA 01606 TEL: (800) 343-7676 FAX: (508) 854-3377 For Parts and information visit us at [www.Curtisindustries.net](http://www.Curtisindustries.net)  
Curtis Industries Inc. LLC, reserves the right to change product design or specifications without notice or liability.  
Curtis Snow Plows are protected by the following U.S. Patent Numbers: 6,145,222 and 6,209,231 Licensed under U.S. Patent Number 5,568,694 & Canadian Patent Number 2,137,853.  
Other patents pending.

## 1FK3B Vehicle Mount Kit Parts List

Item #	Description	Qty.
1	Special Spacer Washer (1-1/4" OD. x 13/16" ID.)	2
2	Driver's Side Bolting Bar	1
3	Passenger's Side Bolting Bar	1
5	Front Mounting Frame	1
5	Driver's Side Push Arm	1
6	Passenger's Side Push Arm	1
<b>Hardware Bag Components Included In This Kit</b>		
7	M12 - 1.75 x 50 mm Bolt Gr. 10.9, Cad., Plated	6
8	M12 Lock Washer, Cad., Plated	6
9	M12 Flat Washer, Cad., Plated	2
10	1/2"-13 x 1-1/2" Bolt, Gr. 5, Cad., Plated	6
11	1/2"-13 x 5-1/2" Bolt, Gr. 5, Cad., Plated	2
12	1/2" Lock Washer, Cad., Plated	8
13	1/2"-13 Hex Nut, Cad., Plated	8
14	5/8"-11 x 2-1/2" Carriage Bolt, Gr. 5, Cad., Plated	2
15	5/8" Lock Washer, Cad., Plated	2
16	5/8" Lock Washer, Cad., Plated	4
17	3/4"-10 x 2" Bolt, Gr. 5, Cad., Plated	2
18	3/4" Lock Washer, Cad., Plated	2
19	3/4" Flat Washer, Cad., Plated	2
20	3/4"-10 Hex Nut, Cad., Plated	2
<b>Hardware Components Included In Plow Light Harness Kit</b>		
-	Dual Plug Harness Bracket	1
-	10-32 x 3/4" Hex Head Screw, Plated	2
-	10-32 Nylock Lock Nut, Plated	2
-	8-32 x 1" Hex Head Screw, Plated	1
-	8-32 Nylock Lock Nut, Plated	1
-	#8 Nylon Flat Washer, 3/4" O.D.	1
-	#8 Flat Washer, SAE, Plated	1



### WARNING

It is highly recommended that front "helper springs", "airshocks", or other similar devices be installed onto this vehicle to prevent the front suspension from "bottoming out" while carrying a snow plow.

Vehicle must be properly "ballasted" by placing ballast weight behind the centerline of Rear Axle so that no more than 62% of the total weight of the Vehicle, Snow Plow, Driver, Ballast weight, (and any cargo) is placed on the Front Axle while at the same time not exceeding the Gross Vehicle Weight Rating and Front or Rear Gross Axle Weight Ratings.

# 1FK3B Mounting

NOTE: Bolts #10, #11, & #17 may be installed in the opposite direction as illustrated with no decrease in effectiveness.

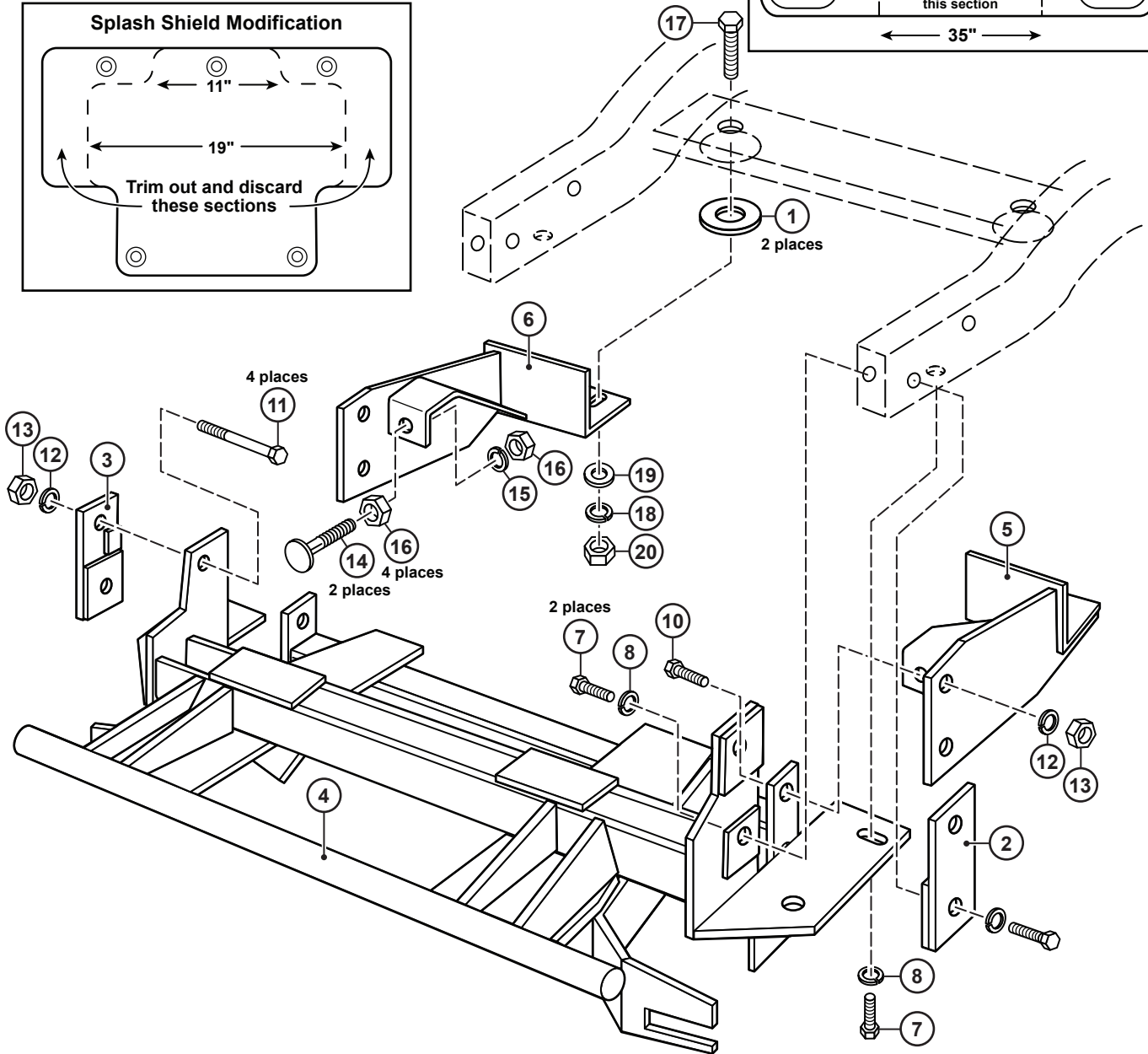
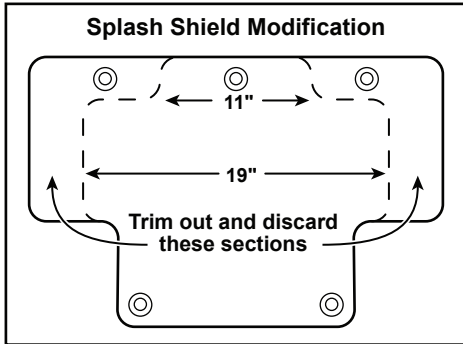
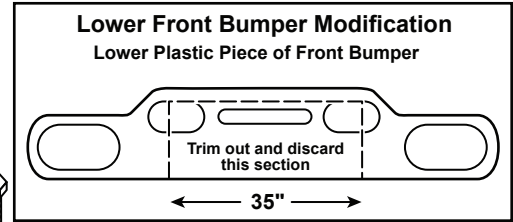

Curtis Industries, LLC. reserves the right to change product design or specifications without notice or liability. Curtis Snow Plows and Truck equipment should only be used on vehicles equipped with the manufacturer's Snow Plow preparation package. Snow Plowing without the original snow plow preparation package may damage your vehicle and the added weight of the equipment may impair the operation and control of the vehicle.

# 1FK3B: 1999 - 2002 GM Silverado / Sierra K-2500 HD 4 x 4

## Mounting Kit Installation Instructions

### 1. VEHICLE PREPARATION

- (1a.) Trim a 35" long section out of the center of the lower plastic piece of the vehicle front bumper. Remove the plastic splash shield attached to the vehicle front suspension cross member and the front tube cross member. Save three of the plastic splash shield metric attaching bolts.
- (1b.) Trim the plastic splash shield according to the diagram included in these installation instructions. (The plastic splash shield will be reinstalled in a later step of the installation).
- (1c.) Remove and discard the six metric bolts holding the tow hooks to the vehicle frame. (Leave the tow hooks in place inside the vehicle boxed frame rails).
- (1d.) Place a 3/4"-10 x 2" bolt (17) down through the outer most hole in each end of the vehicle front suspension cross member. Screw a 5/8"-11 hex jam nut (16) all the way onto each of the 5/8"-11 x 2-1/2" carriage bolts (14). Place each carriage bolt/ jam nut assembly into the push ears on the rear push arms (5 & 6) with the heads of the carriage bolts toward the front of the vehicle. Fasten loosely using a 5/8"-11 hex jam nut (16) and 5/8" lock washer (15) on each carriage bolt / jam assembly.



#### NOTE

All fasteners should remain loose or "finger tight" until all components have been attached to vehicle or installation instructions specify tightening.

### 2. DRIVER'S SIDE PUSH ARM

Place a special spacer washer (1) over the 3/4"-10 x 2" bolt (17) down through the driver's side end of the front suspension cross member, then install the slotted hole in the rear angle bracket of the driver's side push arm (5) on over the bolt. Fasten using a 3/4" flat washer (19), 3/4" lock washer (18), and 3/4"-10 hex nut (20).

### 3. PASSENGER'S SIDE PUSH ARM

Install the passenger's side push arm (6) in the same sequence and with the same type and amount of fasteners as was used in mounting the driver's side push arm.

### 4. FRONT MOUNTING FRAME

- (4a.) Lift the front mounting frame (4) up onto the vehicle frame with the front vertical mounting ears between the frame rails, with the horizontal mounting ears against the bottom flanges of the frame rails and with the rear cross beam between the two side plates of the push arms (5 & 6). Line up the lower holes in the vertical ears with the inner horizontal tow hook bolt holes and fasten by screwing 12mm - 1.75 x 50mm bolts (7), with 12mm lock washers (8) into the threaded tow hook bolt holes.
- (4b.) Place a 1/2"-13 x 5-1/2" bolt (11) through each upper hole in the vertical ears and over the top of the frame rails. Place the upper hole in the driver's side and passenger's side bolting bars (2 & 3) on over end of it's respective 1/2"-13 x 5-1/2" bolt (11) and fasten using 1/2" lock washers (12) and 1/2"-13 hex nuts (13).
- (4c.) Line up the lower holes in the driver's side and passenger's side bolting bars (2 & 3) with the outer horizontal tow hook bolt holes and fasten by screwing 12mm-1.75 x 50mm bolts (7), with 12mm lock washers (8) into the threaded tow hook bolt holes.
- (4d.) Line up the slotted holes in the horizontal mounting ears of the front mounting frame (4) with the vertical tow hook bolt

holes and fasten by screwing 12mm-1.75 x 50mm bolts (7), with 12mm lock washers (8), and 12mm flat washers (9) into the threaded tow hook bolt holes.

- (4e.) Fasten the rear cross beam of the front mounting frame (4) to the side plates of the push arms (5 & 6) using 1/2"-13 x 1-1/2" bolts (10), 1/2" lock washers (12), and 1/2"-13 hex nuts (13).

### 5. DRILLING AND TIGHTENING

- (5a.) Tighten the 12mm bolts (7) holding the front mounting frame (4) to the frame rails and tow hooks. Tighten the 1/2"-13 x 5 1/2" bolts (11) and hex nuts (13) holding the front mounting frame (4) to the driver's side and passenger's side bolting bars (2 & 3). Tighten the 12mm bolts holding the driver's and passenger's side bolting bars (2 & 3) to the frame rails and tow hooks.
- (5b.) Using the remaining holes in the horizontal mounting ears of the front mounting frame (4) as guides, drill a 1/2" dia hole up through each frame rail. Install and tighten a 1/2"-13 x 1-1/2" bolt (10), 1/2" lock washer (12), and 1/2"-13 hex nut (13) into each drilled hole. Tighten the 3/4"-10 hex nuts (20) holding the driver's and passenger's side push arms (5 & 6) to the vehicle front suspension cross member.
- (5c.) Tighten the three 1/2" fasteners holding the push arms (5 & 6) to the rear cross beam of the front mounting frame (4).
- (5d.) Reinstall the trimmed back plastic splash shield using three of the original equipment metric fasteners. Adjust the 5/8"-11 x 2-1/2" carriage bolts (14) with the front 5/8"-11 jam nuts (16) so that the heads of the carriage bolts are tight against the back of the rear cross tube of the front mounting frame (4). Lock the 5/8"-11 x 2 1/2" carriage bolts (14) in place using the rear 5/8"-11 jam nuts (16).

### 6. FINAL ADJUSTMENT AND INSPECTION

Inspect the mounting attachment bolts to be certain that they are all in place and that they are all tight.

### 7. OPTIONAL PLUG MOUNT BRACKET INSTALL



#### NOTE

Install the Plug Mount Bracket if the harness will be mounted on the frame kit, otherwise, the harness may be routed through the grill, bumper, etc.

Using (2) 10-32 x 3/4" hex bolts and nylon locknuts, fasten the Plug Mount Bracket to the Plug Mount Bracket Mounting Tab located on the driver's side of the frame kit receiver. The included 8-32 hardware is used for mounting the hi-amp battery leads to the Plug Mount Bracket if used.

