

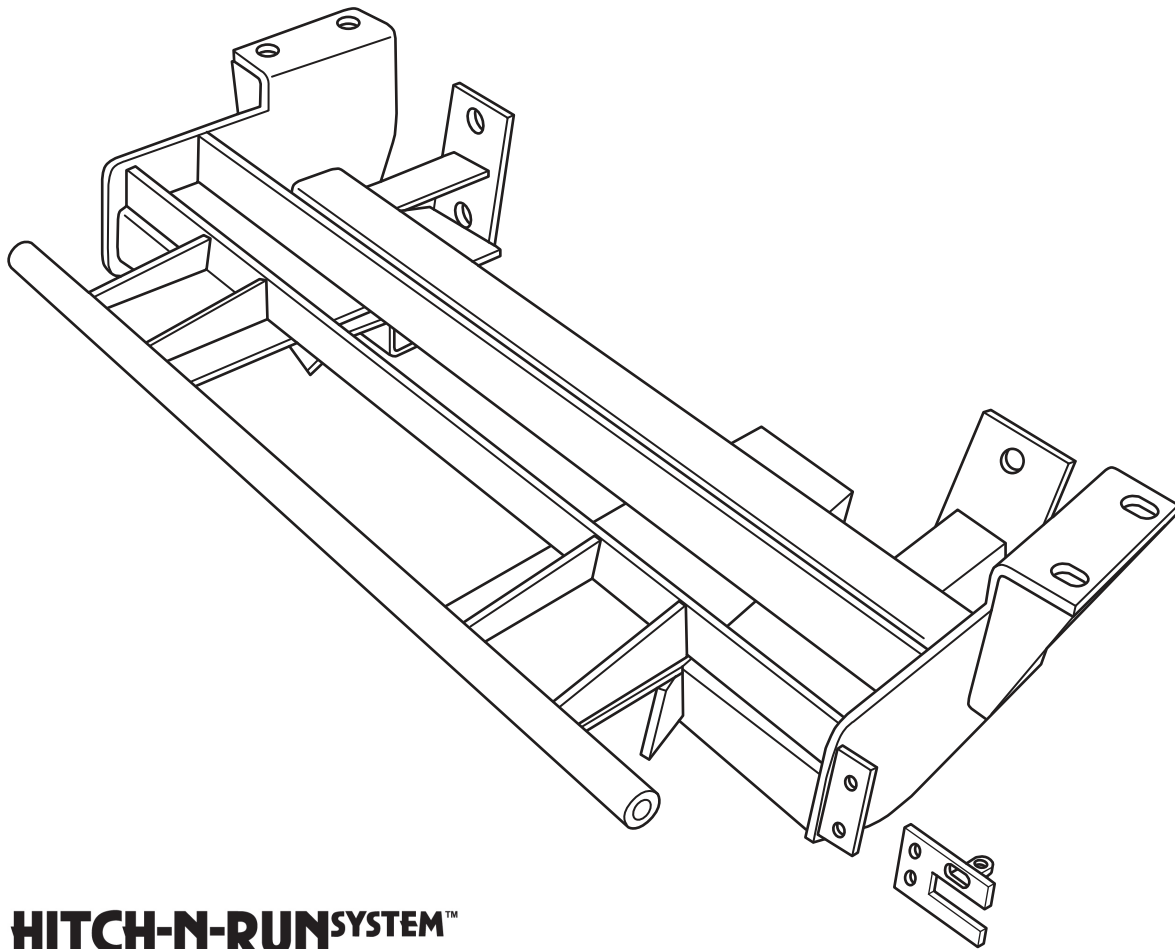

# HOME-PRO<sup>®</sup> 3000

**2005 - 2006 Nissan Frontier 4x4 Club Cab  
(With Max. GVWR & Max. FGAWR ONLY)**

**Vehicle Mounting Kit: 1FK39**



Curtis Industries Inc. LLC, 111 Higgins St., Worcester, MA 01606 TEL: (800) 343-7676 FAX: (508) 854-3377 For Parts and information visit us at [www.Curtisindustries.net](http://www.Curtisindustries.net)  
Curtis Industries Inc. LLC, reserves the right to change product design or specifications without notice or liability.  
Curtis Snow Plows are protected by the following U.S. Patent Numbers: 6,145,222 and 6,209,231 Licensed under U.S. Patent Number 5,568,694 & Canadian Patent Number 2,137,853.  
Other patents pending.

## 1FK39 Vehicle Mount Kit Parts List

Item #	Description	Qty.
1	Mounting Frame	1
2	3/4" x 2" Pipe Spacers	4
<b>Hardware Bag Components Included In This Kit</b>		
3	12mm x 1.25mm x 40mm, Gr.8.8, Plated	4
4	12mm Lock Washers, Plated, High Strength	8
5	12mm Flat Washer, Plated	8
6	12mm x 1.25mm x 85mm, Gr.8.8, Plated	4
<b>Hardware Components Included In Plow Light Harness Kit</b>		
1a	Dual Plug Harness Bracket	1
-	10-32 x 3/4" Hex Head Screw, Plated	2
-	10-32 Nylock Lock Nut, Plated	2
-	8-32 x 1" Hex Head Screw, Plated	1
-	8-32 Nylock Lock Nut, Plated	1
-	#8 Nylon Flat Washer, 3/4" O.D.	1
-	#8 Flat Washer, SAE, Plated	1



### WARNING

It is highly recommended that front "helper springs", "airshocks", or other similar devices be installed onto this vehicle to prevent the front suspension from "bottoming out" while carrying a snow plow.

Vehicle must be properly "ballasted" by placing ballast weight behind the centerline of Rear Axle so that no more than 62% of the total weight of the Vehicle, Snow Plow, Driver, Ballast weight, (and any cargo) is placed on the Front Axle while at the same time not exceeding the Gross Vehicle Weight Rating and Front or Rear Gross Axle Weight Ratings.

# 1FK39 Mounting

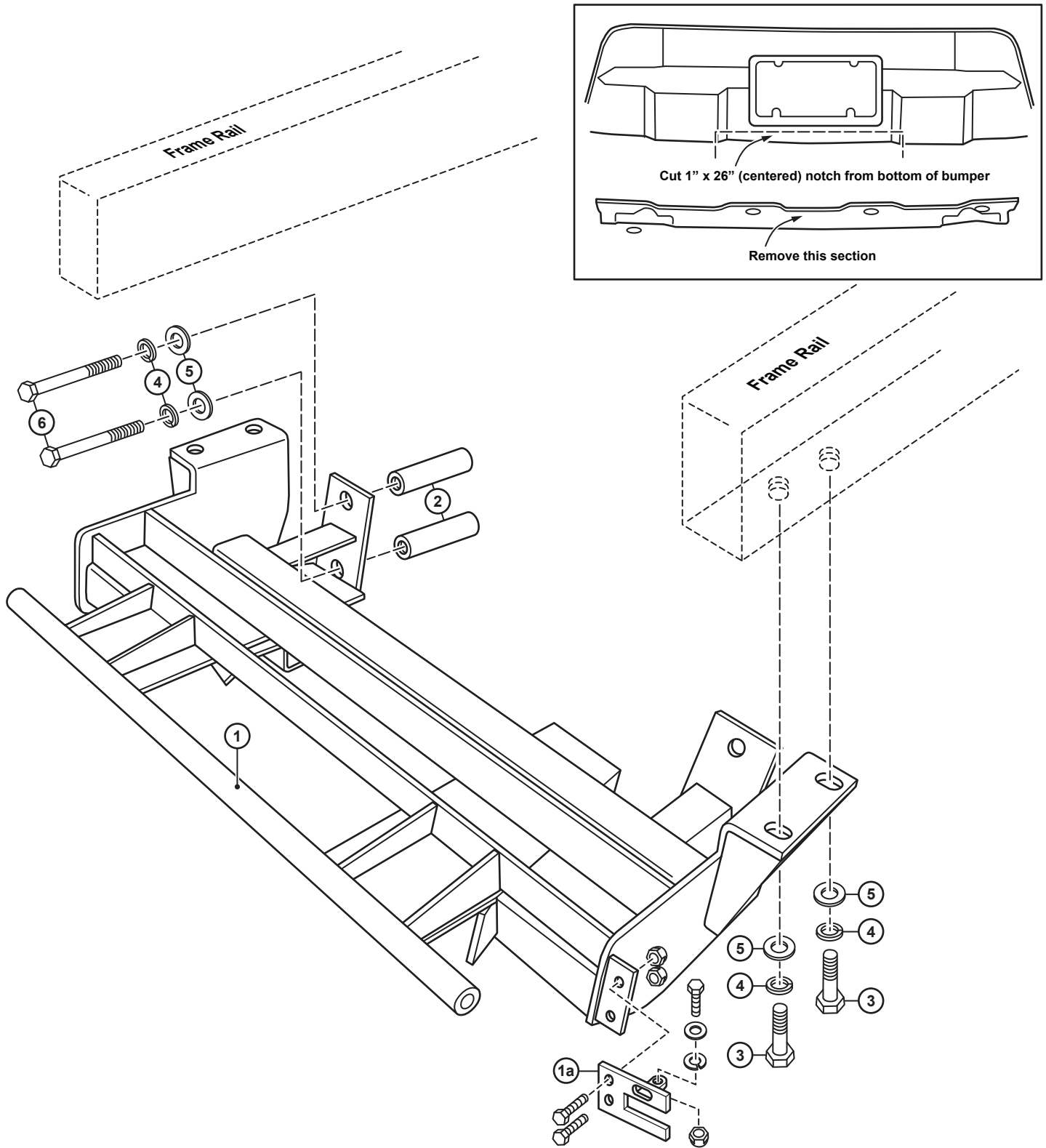

*Curtis Industries, LLC. reserves the right to change product design or specifications without notice or liability. Curtis Snow Plows and Truck equipment should only be used on vehicles equipped with the manufacturer's Snow Plow preparation package. Snow Plowing without the original snow plow preparation package may damage your vehicle and the added weight of the equipment may impair the operation and control of the vehicle.*

# 1FK39: 2005 - 2006 Nissan Frontier 4x4 Club Cabt

## Mounting Kit Installation Instructions

### 1. VEHICLE PREPARATION

- (1a.) Remove and store the original equipment front splash pan, and the removable lower section of the vehicle's front bumper that is bolted in place with four 10mm screws. Also remove the tow hook / tie down bracket & fasteners on the passenger's side frame rail just behind the front bumper. Save all the original equipment parts and fasteners for possible reinstallation if the plow mounting is removed. The splash pan, tie down brackets, tow hook, and fasteners will not be re-installed with the mounting frame (1) attached.
- (1b.) Loosen all four sway bar bolts, only remove three of these bolts at this time, leave one bolt holding the swaybar in place.
- (1c.) Cut a 1" x 26" section out of the lower section of the vehicles front bumper. See diagram in exploded view.
- (1d.) Remove the two horizontal 14mm bolts and nuts holding the front bumper brackets to each frame rail. Remove the tow hook fasteners and tow hooks. The original equipment bumper bracket and tow hook fasteners will not be reused with the plow mount. Place a 3/4"-10 x 2" bolt (16) down through the outer most hole in each end of the front suspension cross member.



**NOTE**

All fasteners should remain loose or "finger tight" until all components have been attached to Vehicle or installation instructions specify tightening.

**IMPORTANT**

If the plow mounting frame (1) is ever removed from the vehicle, the original equipment skid / splash pan must be reinstalled before the vehicle is put back into service.

### 2. MOUNTING FRAME

- (2a.) Lift the mounting frame (1) up to the bottom of the vehicle frame rails so the four vertical bolt holes line up with the threaded tow hook holes on the bottom of the frame rails. Attach mounting frame with four 12mm x 1.25 x 40mm bolts (3), 12mm lockwashers(4), and 12mm flat washers (5).
- (2b.) Lift the mounting frame (1) up to the bottom of the vehicle frame rails so the four vertical bolt holes line up with the threaded tow hook holes on the bottom of the frame rails. Attach mounting frame with four 12mm x 1.25 x 40mm bolts (3), 12mm lockwashers(4), and 12mm flat washers (5).

### 3. FINAL ADJUSTMENT AND INSPECTION

Inspect the mounting attachment and original equipment bolts to be certain that they are all in place and that they are all tight.

### 4. OPTIONAL PLUG MOUNT BRACKET INSTALL



**NOTE**

Install the Plug Mount Bracket if the harness will be mounted on the frame kit, otherwise, the harness may be routed through the grill, bumper, etc.

Using (2) 10-32 x 3/4" hex bolts and nylon locknuts, fasten the Plug Mount Bracket to the Plug Mount Bracket Mounting Tab located on the drivers side of the frame kit receiver. The included 8-32 hardware is used for mounting the hi-amp battery leads to the Plug Mount Bracket, if used.

