

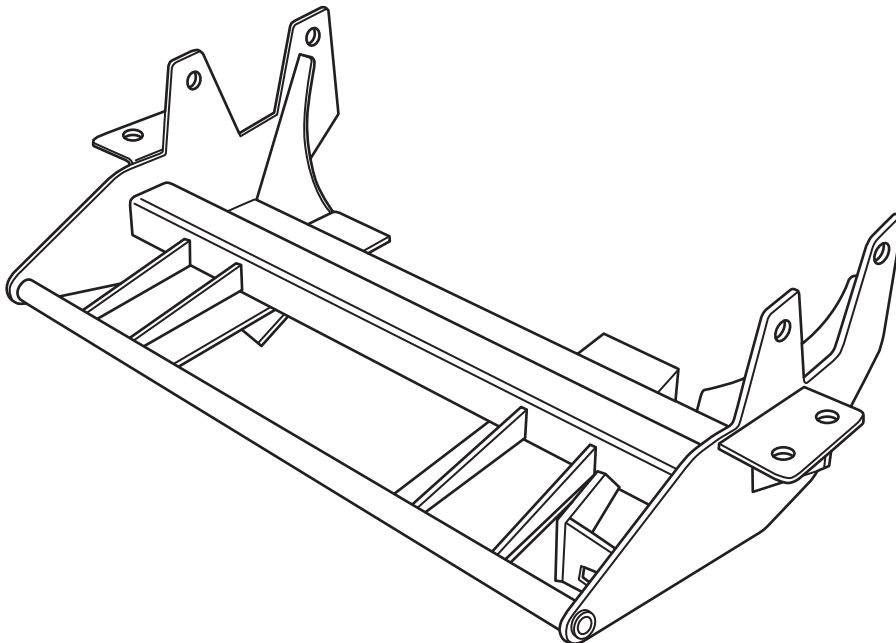

SNO-PRO[®] 3000

**2004 – Ford F-150 4 x 4
(With Snow Plow Prep. Package ONLY)**

Vehicle Mounting Kit: 1FK26



Curtis Industries Inc. LLC, 111 Higgins St., Worcester, MA 01606 TEL: (800) 343-7676 FAX: (508) 854-3377 For Parts and information visit us at www.Curtisindustries.net
Curtis Industries Inc. LLC, reserves the right to change product design or specifications without notice or liability.
Curtis Snow Plows are protected by the following U.S. Patent Numbers: 6,145,222 and 6,209,231 Licensed under U.S. Patent Number 5,568,694 & Canadian Patent Number 2,137,853.
Other patents pending.

1FK26 Vehicle Mount Kit Parts List

Item #	Description	Qty.
1	Mounting Frame Weldment	1
2	1/2" x 2-3/8" Pipe Spacer with Handle	2
3	5/8" x 2-5/16" Pipe Spacer	2
Hardware Bag Components Included In This Kit		
4	1/2"-13 x 5" Bolt, Gr. 5, Cad., Plated	2
5	5/8"-11 x 5-1/2" Bolt, Gr. 5, Cad., Plated	2
6	1/2" Flat Washer, Cad., Plated	2
7	1/2" Lock Washer, Cad., Plated	2
8	1/2"-13 Hex Nut, Cad., Plated	2
9	5/8" Flat Washer, Cad., Plated	2
10	5/8" Lock Washer, Cad., Plated	2
11	5/8"-11 Hex Nut, Cad., Plated	2



WARNING

It is highly recommended that front "helper springs", "airshocks", or other similar devices be installed onto this vehicle to prevent the front suspension from "bottoming out" while carrying a snow plow.

Vehicle must be properly "ballasted" by placing ballast weight behind the centerline of Rear Axle so that no more than 62% of the total weight of the Vehicle, Snow Plow, Driver, Ballast weight, (and any cargo) is placed on the Front Axle while at the same time not exceeding the Gross Vehicle Weight Rating and Front or Rear Gross Axle Weight Ratings.

1FK26 Mounting

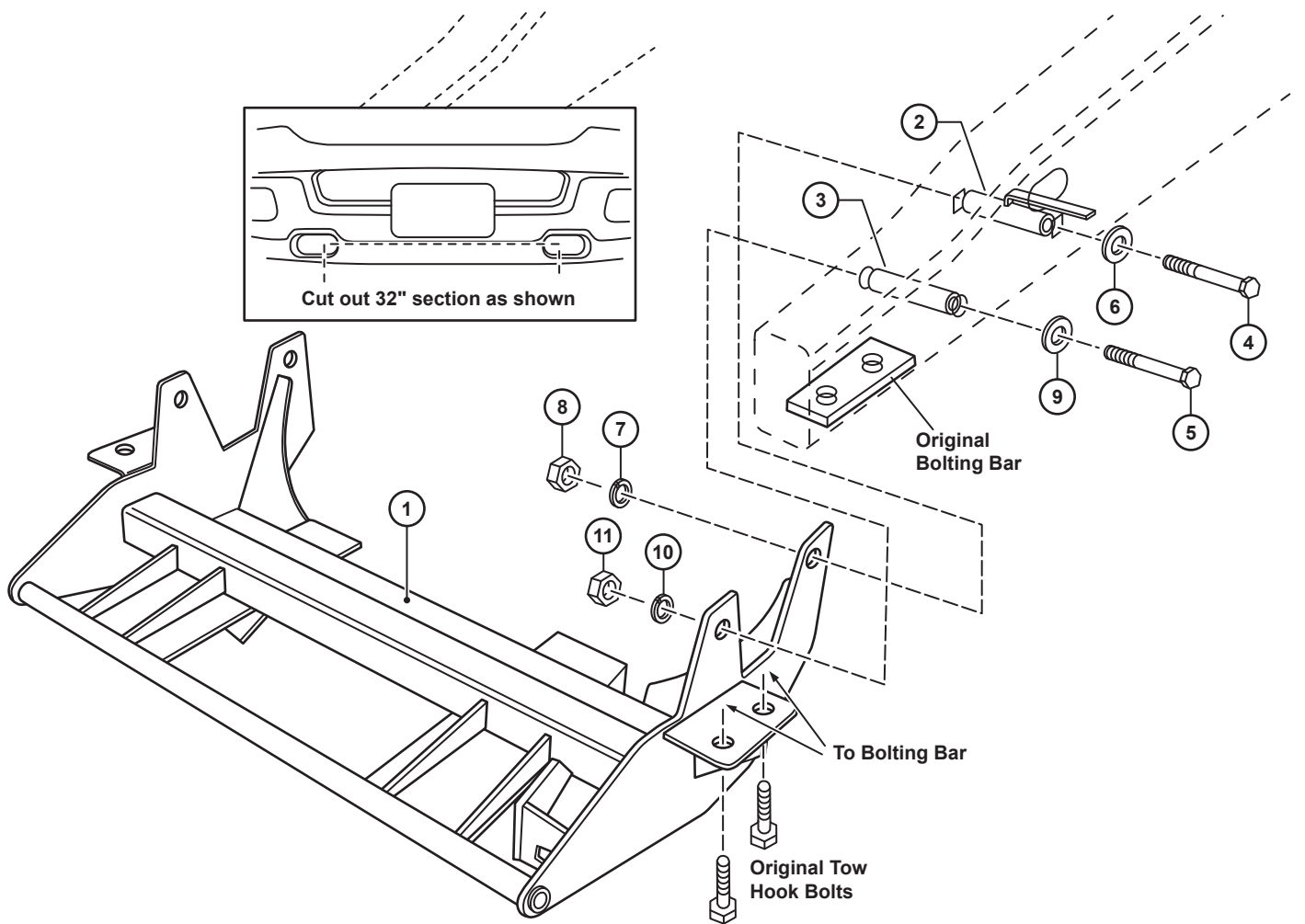

Curtis Industries, LLC. reserves the right to change product design or specifications without notice or liability. Curtis Snow Plows and Truck equipment should only be used on vehicles equipped with the manufacturer's Snow Plow preparation package. Snow Plowing without the original snow plow preparation package may damage your vehicle and the added weight of the equipment may impair the operation and control of the vehicle.

1FK26: 2004- Ford F-150 4x4

Mounting Kit Installation Instructions

1. VEHICLE PREPARATION

- (1a.) Remove and store the vehicle (front) tow hooks. Leave the threaded tow hook bolting bars in place inside the frame rails and save the tow hook bolts. The tow hook bolts and bolting bars will be reused to install the plow mounting frame (1). The tow hooks will not be reinstalled with the mounting frame (1) in place.
- (1b.) Trim out a piece of the lower plastic section of the front bumper 32" long and up even with the lower rear steel flange of the bumper.



NOTE

All fasteners should remain loose or "finger tight" until all components have been attached to Vehicle or installation instructions specify tightening.

2. MOUNTING FRAME

- (2a.) Lift the mounting frame (1) up under the front of the vehicle with the vertical side plates between the inner walls of the frame rails and with the horizontal bolting plates against the bottom walls of the frame rails. Line up the holes in the horizontal bolting plates of the mounting frame (1) with the tow hook bolt holes in the frame rails. Fasten loosely using the original equipment tow hook bolts threaded into the bolting bars inside the frame rails.
- (2b.) Place a 5/8" flat washer (9) and pipe spacer (3) onto each of the 5/8"-13 x 5-1/2" bolts (5) then insert through the large hole in the outer wall of each frame rail just behind the bumper mounting flange continue through the inner walls with the threaded ends of the bolts through the front hole in each vertical side plate of the mounting frame (1). Fasten each side loosely using a 5/8" lock washer (10) and 5/8"-13 nut (11).
- (2c.) Place a pipe spacer (with handle) (2) into each frame rail through the large slotted hole under the radiator web/body mount bracket on the outer walls of the rails. Place a 1/2" flat washer (6) onto each of the 1/2"-13 x 5" bolts (4) and insert each through the square hole in the outer wall of each frame rail just below the large slotted hole that the pipe spacers (with handle) (2) were placed into. Continue inserting the 1/2"-13 x 5" bolts (4) through the pipe spacers (with handle) (2), and the square hole in the inner walls of the frame rails with the threaded ends through the rear holes in the vertical side plates of the mounting frame (1). Fasten each side loosely using 1/2" lock washers (7) and 1/2"-13 nuts (8).

3. TIGHTENING

Make certain that the pipe spacers (3) are positioned correctly through the holes in both the inner and outer walls of each frame rail, then tighten the original equipment tow hook bolts installed through the horizontal bolting plates of the mounting frame (1). Tighten the remaining 1/2" and 5/8" fasteners holding the mounting frame (1) to the frame rails.

IMPORTANT

The frame rail can be crushed while tightening the 1/2" and 5/8" fasteners if the pipe spacers (2) (3) are not installed or are installed improperly.

4. FINAL ADJUSTMENT AND INSPECTION

Bend over the ends of the handles on the pipe spacers (with handles) (2) that protrude from the slotted hole in each frame rail. Return the tow hooks with the vehicle so they can be reinstalled if the mounting frame is removed. Inspect the mounting frame (1) attachment bolts to be certain that they are all in place and that they are all tight.

