

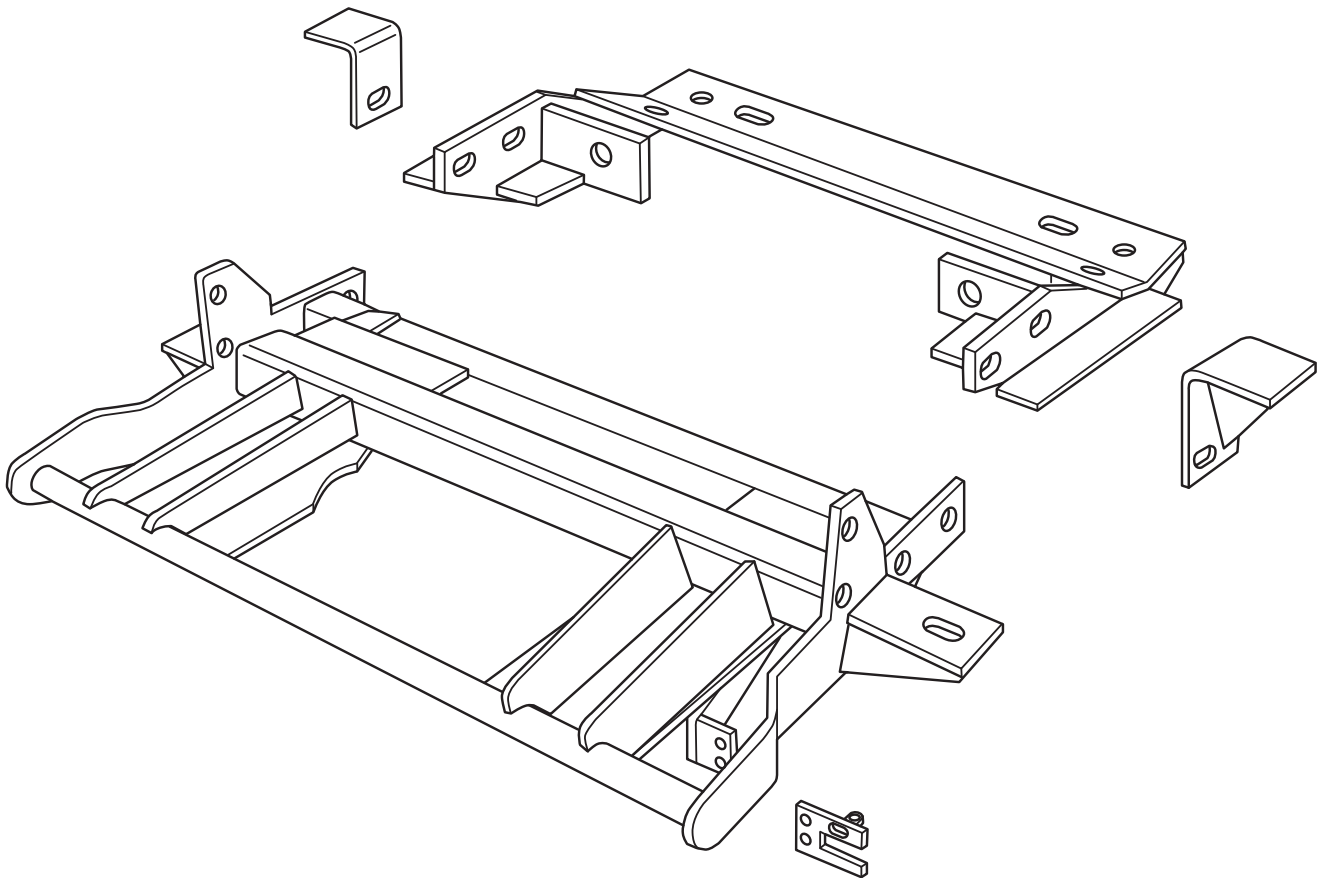

SNO-PRO[®] 3000

**2003 – GM Silverado / Sierra K-1500
(4 x 4 With VYU ONLY)**

Vehicle Mounting Kit: 1FK23



Curtis Industries Inc. LLC, 111 Higgins St., Worcester, MA 01606 TEL: (800) 343-7676 FAX: (508) 854-3377 For Parts and information visit us at www.Curtisindustries.net
Curtis Industries Inc. LLC, reserves the right to change product design or specifications without notice or liability.
Curtis Snow Plows are protected by the following U.S. Patent Numbers: 6,145,222 and 6,209,231 Licensed under U.S. Patent Number 5,568,694 & Canadian Patent Number 2,137,853.
Other patents pending.

1FK23 Vehicle Mount Kit Parts List

Item #	Description	Qty.
1	Front Mounting Weldment	1
2	Rear Mounting Weldment	1
3	Driver's Side Support Angle Weldment	1
4	Passenger's Side Support Angle Weldment	1
Hardware Bag Components Included In This Kit		
5	M10-1.5 x 35mm Bolt, Gr. 10.9, Plated	2
6	M10 Lock Washer, Plated	2
7	M10 Flat Washer, Plated	2
8	M12-1.75 x 35mm Bolt Gr. 10.9, Plated	2
9	M12 Lock Washer, High Strength, Plated	2
10	M12 Flat Washer, Plated	2
11	1/2"-13 x 5-1/2" Bolt, Gr. 5, Plated	2
12	1/2"-13 x 1-1/2" Bolt, Gr. 5, Plated	8
13	1/2" Lock Washer, Plated	10
14	1/2" Flat Washer, Plated	8
15	1/2"-13 Hex Nut, Plated	10
16	5/8"-11 x 2-1/2" Carriage Bolt, Gr. 5, Plated	2
17	5/8" Lock Washer, Plated	2
18	5/8"-11 Hex Jam Nut, Plated	4
Hardware Components Included In Plow Light Harness Kit		
1a	Plug Mount Bracket	1
-	10-32 x 3/4" Hex Head Screw, Plated	2
-	10-32 Nylock Lock Nut, Plated	2
-	8-32 x 1" Hex Head Screw, Plated	1
-	8-32 Nylock Lock Nut, Plated	1
-	#8 Nylon Flat Washer, 3/4" O.D.	1
-	#8 Flat Washer, SAE, Plated	1



WARNING

It is highly recommended that front "helper springs", "airshocks", or other similar devices be installed onto this vehicle to prevent the front suspension from "bottoming out" while carrying a snow plow.

Vehicle must be properly "ballasted" by placing ballast weight behind the centerline of Rear Axle so that no more than 62% of the total weight of the Vehicle, Snow Plow, Driver, Ballast weight, (and any cargo) is placed on the Front Axle while at the same time not exceeding the Gross Vehicle Weight Rating and Front or Rear Gross Axle Weight Ratings.

1FK23 Mounting

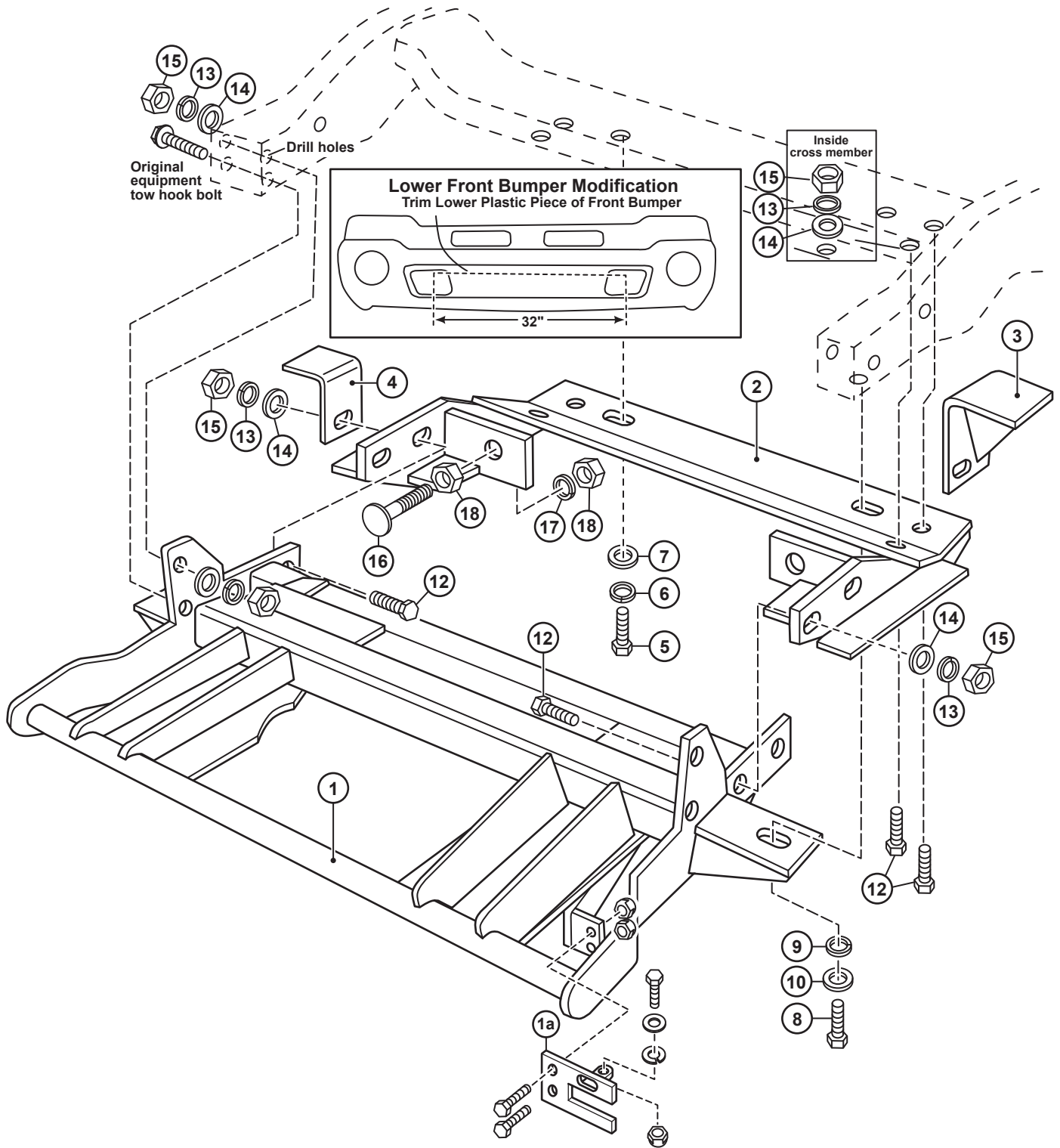

Curtis Industries, LLC. reserves the right to change product design or specifications without notice or liability. Curtis Snow Plows and Truck equipment should only be used on vehicles equipped with the manufacturer's Snow Plow preparation package. Snow Plowing without the original snow plow preparation package may damage your vehicle and the added weight of the equipment may impair the operation and control of the vehicle.

1FK23: 2003- GM Silverado / Sierra K-1500

Mounting Kit Installation Instructions

1. VEHICLE PREPARATION

- (1a.) Temporarily remove the plastic cover between the vehicle grill and radiator web, the vehicle grill, and the vehicle front bumper. Save all pieces and fasteners for reinstallation. Trim a 32" long section (For Chevrolet: 1-1/2" down from the seam between the steel and plastic.) (For GMC: at the seam between the steel and plastic.) out of the center of the lower plastic piece of the vehicle front bumper.
- (1b.) Remove and save the metric nuts from the horizontal bolts holding the tow hooks to the frame rails. Pull back the horizontal tow hook bolts so that the ends clear the inside surfaces of the frame rails (Leave the tow hooks in place inside the vehicle boxed frame rails). Remove and discard the vertical metric bolts holding the tow hooks to the frame rails. Remove and discard the two metric bolts holding the plastic splash shield to the front suspension cross member. Remove and save the three metric bolts holding the plastic splash shield to the front round tube cross member. Remove and save the plastic splash shield.
- (1c.) Screw a 5/8"-11 hex jam nut (19) all the way onto each of the 5/8"-11 x 2-1/2" carriage bolts (17). Place each carriage bolt / jam nut assembly into the push ears of the rear mounting weldment (2) with the heads of the carriage bolts toward the front of the vehicle. Fasten loosely using a 5/8"-11 hex jam nut (19) and 5/8" lock washer (18) on each carriage bolt / jam assembly.



NOTE

All fasteners should remain loose or "finger tight" until all components have been attached to vehicle or installation instructions specify tightening.

2. REAR PUSH WELDMENT

- (2a.) Place the lower section of the plastic splash shield into the rear mounting weldment (2) with the two holes in the lower section lined up with the two slotted holes in the rear bar of the weldment (2). (The lower section of the plastic splash shield should now be under the rear bar of the of the rear mounting weldment.) Lift the rear mounting weldment (2) and the plastic splash shield as an assembly up onto the bottom of the front suspension cross member. Fasten using M10-1.5 x 35 mm Bolts (5), M10 flat washers (7), and M10 lock washers (6) up through the two holes in the lower section of the plastic splash shield, through the two slotted holes in the rear bar of the rear mounting weldment (2), and threaded into the tapped holes in the front suspension cross member.
- (2b.) Attach the upper section of the plastic splash shield to the front tube cross member using the three original equipment metric bolts removed earlier.

3. FRONT MOUNTING WELDMENT

- (3a.) Lift the front mounting weldment (1) up onto the vehicle frame with the front vertical ears between the frame rails and with the rear cross beam between the two side plates of the rear mounting weldment (2). Line up the lower holes in the vertical ears with the horizontal tow hook bolts and slide the bolts through the ears. Reinstall the metric nuts removed earlier back onto the horizontal tow hook bolts. Fasten the horizontal ears of the front mounting weldment (1) using M12-1.75 x 35 bolts (8), M12 flat washers (10), and M12 lock washers (9) up through the ears, through the frame rails, and threaded into the tapped holes in the tow

hooks.

- (3b.) Fasten the front holes of the rear cross beam of the front mounting weldment (1) to the side plates of the rear mounting weldment (2) using 1/2"-13 x 1-1/2" bolts (13), 1/2" flat washers (15), 1/2" lock washers (14), and 1/2"-13 hex nuts (16).
- (3c.) Place the hole in the Driver's side and Passenger's side support angles (3) & (4) over the rear hole in the side plates of the rear mounting frame (2) with the upper ends of the support angles (3) & (4) under the frame rails. Fasten using 1/2"-13 x 2" bolts (12), 1/2" flat washers (15), 1/2" lockwashers (14), and 1/2"-13 nuts (16).

4. DRILLING AND TIGHTENING

- (4a.) Tighten the two M10 metric bolts (5) holding the rear mounting weldment (2) and plastic splash shield to the front suspension cross member and the three original equipment M10 metric bolts holding the plastic splash shield to the front tube cross member. Tighten all the tow hook bolts and nuts. Tighten the four 1/2"-13 bolts (12 & 13), and hex nuts (16) holding the rear mounting weldment (2), and support angle weldments (3) & (4) to the front mounting weldment (1).
- (4b.) Using the four open holes in the rear cross bar of the rear mounting weldment (2) as guides, drill four 1/2" holes in the front suspension cross member. Install and tighten four 1/2"-13 x 1-1/2" bolts (13), 1/2" flat washers (15), 1/2" lockwashers (14) and 1/2"-13 hex nuts (16) in the drilled holes in the front suspension cross member. (The 1/2" flat washers (14) should be inside the cross member.)
- (4c.) Using the remaining open hole in each vertical ear of the front mounting weldment (1) as a guide, drill a 1/2" hole through the inner surface and out through the hole in the outer surface of each frame rail. Insert a 1/2"-13 x 5-1/2" bolt (11) through each vertical ear of the front mounting frame (1) and out through the drilled hole in each frame rail. Fasten and tighten using 1/2" lock washers (14), and 1/2"-13 hex nuts (16). Adjust the 5/8"-11 x 2-1/2" carriage bolts (17) with the front 5/8"-11 jam nuts (19) so that the heads of the carriage bolts are tight against the back of the rear cross tube of the front mounting frame (1). Lock the 5/8"-11 x 2-1/2" carriage bolts (17) in place using the rear 5/8"-11 jam nuts (19).
- (4d.) Install the vehicle side plow wiring harness and plow light wiring adapters at this time. Reinstall and tighten the front bumper, the grill, and the plastic cover between the grill and radiator web using the original equipment fasteners.

5. FINAL ADJUSTMENT AND INSPECTION

Inspect the mounting attachment bolts to be certain that they are all in place and that they are all tight.

