

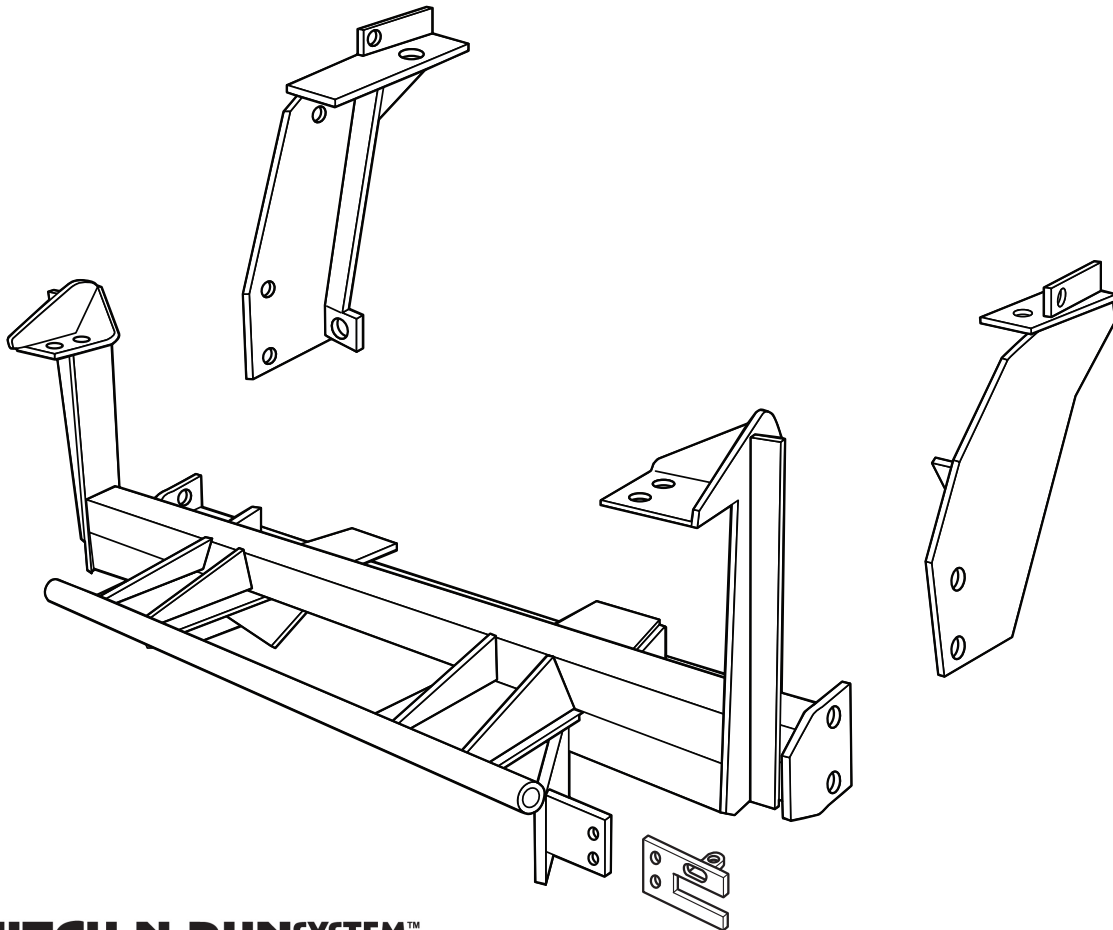

HOME-PRO[®] 3000

**1997 – Jeep Wrangler
(With Max. GVWR & Max. FGAWR ONLY)**

Vehicle Mounting Kit: 1FK15



Curtis Industries Inc. LLC, 111 Higgins St., Worcester, MA 01606 TEL: (800) 343-7676 FAX: (508) 854-3377 For Parts and information visit us at www.Curtisindustries.net
Curtis Industries Inc. LLC, reserves the right to change product design or specifications without notice or liability.
Curtis Snow Plows are protected by the following U.S. Patent Numbers: 6,145,222 and 6,209,231 Licensed under U.S. Patent Number 5,568,694 & Canadian Patent Number 2,137,853.
Other patents pending.

1FK15 Vehicle Mount Kit Parts List

Item #	Description	Qty.
1	Front Mount Frame	1
2	Driver's Side Push Arm	1
3	Passenger's Side Push Arm	1
4	1/4" (Thick) x 2" x 2" Square Washer	2
Hardware Bag Components Included In This Kit		
5	1/2"-13 x 1-1/2" Bolt, Gr.5, Plated	8
6	1/2"-13 x 4-1/2" Bolt, Gr.5, Plated	2
7	1/2" Lock Washer, Plated	10
8	1/2"-13 Hex Nut, Plated	6
9	1/2" Flat Washer, Plated	2
10	5/8"-11 x 2-1/2" Carriage Bolt Gr.5, Plated	2
11	5/8"-11 x 5-1/2" Bolt Gr.5, Plated	2
12	5/8" Lock Washer, Plated	4
13	5/8"-11 Hex Jamb Nut, Plated	4
14	5/8"-11 Hex Nut, Plated	2
Hardware Components Included In Plow Light Harness Kit		
1a	Dual Harness Plug Mount Bracket	1
-	10-32 x 3/4" Hex Head Screw, Plated	2
-	10-32 Nylock Lock Nut, Plated	2
-	8-32 x 1" Hex Head Screw, Plated	1
-	8-32 Nylock Lock Nut, Plated	1
-	#8 Nylon Flat Washer, 3/4" O.D.	1
-	#8 Flat Washer, SAE, Plated	1



WARNING

It is highly recommended that front "helper springs", "airshocks", or other similar devices be installed onto this vehicle to prevent the front suspension from "bottoming out" while carrying a snow plow.

Vehicle must be properly "ballasted" by placing ballast weight behind the centerline of Rear Axle so that no more than 62% of the total weight of the Vehicle, Snow Plow, Driver, Ballast weight, (and any cargo) is placed on the Front Axle while at the same time not exceeding the Gross Vehicle Weight Rating and Front or Rear Gross Axle Weight Ratings.

1FK15 Mounting

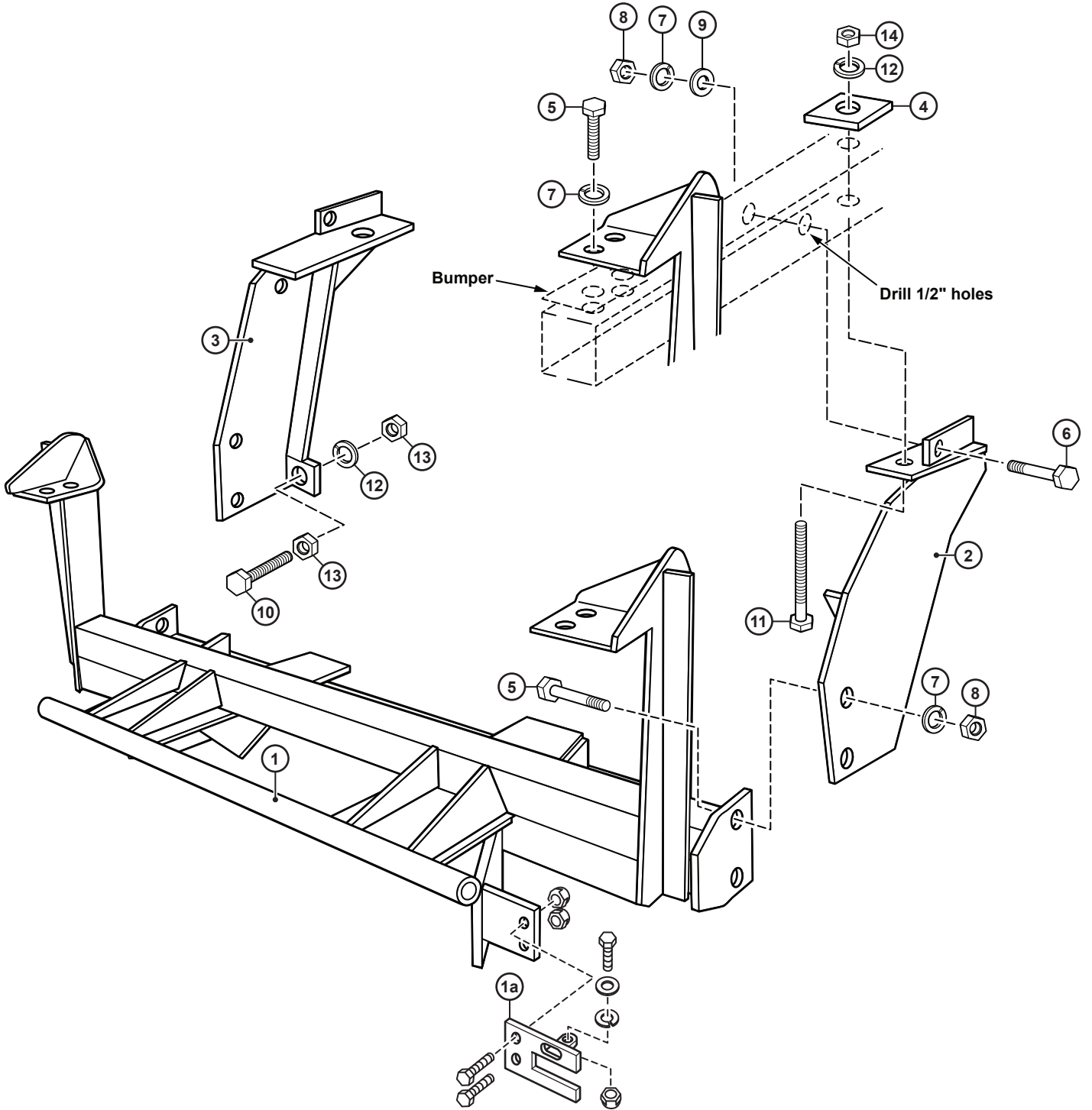

Curtis Industries, LLC. reserves the right to change product design or specifications without notice or liability. Curtis Snow Plows and Truck equipment should only be used on vehicles equipped with the manufacturer's Snow Plow preparation package. Snow Plowing without the original snow plow preparation package may damage your vehicle and the added weight of the equipment may impair the operation and control of the vehicle.

1FK15: 1997 – Jeep Wrangler

Mounting Kit Installation Instructions

1. VEHICLE PREPARATION

- (1a.) Temporarily remove the vehicle front bumper. Discard the four Torx head 1/2" bolts holding the top surface of the bumper to the frame rails, save the two Torx head 1/2" bolts holding the bottom surface of the bumper to the frame rails for later reinstallation.
- (1b.) Screw a 5/8"-11 hex jamb nut (13) all the way onto each of the 5/8"-11 x 2-1/2" carriage bolts (10). Place each carriage bolt / jam nut assembly through the ears on the driver's side and passenger's side push arms (2) & (3) with the heads of the carriage bolts toward the front of the vehicle. Fasten loosely using a 5/8" lock washer (12) and 5/8"-11 hex jamb nut (13) on each carriage bolt / jam nut assembly.



NOTE

All fasteners should remain loose or "finger tight" until all components have been attached to vehicle or installation instructions specify tightening.

2. MOUNTING FRAME

- (2a.) Lift the mounting frame (1) up onto the vehicle frame so that the bolting ears of the front vertical brackets are on top of the frame rails with the holes in the ears lined up with the tapped bumper mounting holes in the top surface of the rails. Block up under the mounting frame (1) to temporarily hold it in position.
- (2b.) Place the vehicle front bumper back into position on the frame rails with the bolting ears on the front vertical brackets of the mounting frame (1) on top of the top surface of the bumper. Fasten using four 1/2"-13 x 1-1/2" bolts (5), and 1/2" lock washers (7) through the bolting ears of the mounting frame (1), through the bumper mounting holes in the top surface of the bumper, threaded into the tapped bumper mounting holes in the frame rails.
- (2c.) Reinstall the two Torx head 1/2" bolts removed previously back into the bottom surface of the bumper and frame rail. Remove the temporary blocking from under the mounting frame (1).

3. DRIVER'S SIDE PUSH ARM

- (3a.) Place the horizontal bolting bracket on the upper section of the Driver's side push arm (2) against the bottom surface of the Driver's side frame rail just ahead of the coil spring mount. Line up the hole in the horizontal bolting bracket of the push arm with the hole in the bottom surface of the frame rail. Fasten using a 5/8"-11 x 5-1/2" bolt (11) up through the bolting bracket, through the bottom surface and top surface of the frame rail with a square washer (4), 5/8" lock washer (12), and 5/8"-11 hex nut (14) on top of the frame rail.
- (3b.) Align the two holes in the lower front section of the push arm (2) with the two holes in the end plate on the rear tube of the mounting frame (1). Fasten using two 1/2"-13 x 1-1/2" bolts (5), 1/2" lock washers (7), and 1/2"-13 hex nuts (8).

IMPORTANT

If mounting frame (1) and new skid / splash pan (2) are ever removed from the vehicle, the original equipment skid / splash pan must be reinstalled before the vehicle is put back into service.

4. PASSENGER'S SIDE PUSH ARM

Install the Passenger's side push arm (3) in exactly the same sequence and with the same type and amount of fasteners as used with the Driver's side push arm (2).

5. DRILLING & TIGHTENING

- (5a.) Align the vehicle front bumper then tighten the six bumper bolts and all other bolts installed in the mounting frame (1) and push arms (2) & (3) up to this point.
- (5b.) Using the remaining open hole in the vertical bolting ear on the upper section of each push arm (2) & (3) as a guide, drill a 1/2" dia. hole through the outer and inner surface of each frame rail. Fasten at the drilled holes using a 1/2"-13 x 4-1/2" bolt (6) through the vertical bolting ear on the upper section of each push arm (2) & (3), through the outer and inner surface of each frame rail, with a 1/2" flat washer (9), 1/2" lock washer (7), and 1/2"-13 hex nut (8) on the inside of each rail.
- (5c.) Tighten the 1/2" fasteners installed at the drilled holes being careful to not over torque the nuts and crush the frame rails. Adjust the 5/8"-11 x 2-1/2" carriage bolts (10) with the front 5/8"-11 jamb nuts (13) so that the heads of the carriage bolts are tight against the back of the rear cross tube of the mounting frame (1). Lock the 5/8"-11 x 2-1/2" carriage bolts (10) in place using the rear 5/8"-11 jamb nuts (13).
- (5d.) Inspect the mounting frame, bumper bracket, and push arm attachment bolts to be certain that they are all in place and that they are all tight.

6. FINAL ADJUSTMENT AND INSPECTION

Inspect the mounting and skid / splash pan attachment bolts to be certain that they are all in place and that they are all tight.

7. OPTIONAL PLUG MOUNT BRACKET INSTALL



NOTE

Install the Plug Mount Bracket if the harness will be mounted on the frame kit, otherwise, the harness may be routed through the grill, bumper, etc.

Using (2) 10-32 x 3/4" hex bolts and nylon locknuts, fasten the Plug Mount Bracket to the Plug Mount Bracket Mounting Tab located on the driver's side of the frame kit receiver. The included 8-32 hardware is used for mounting the hi-amp battery leads to the Plug Mount Bracket if used.

