

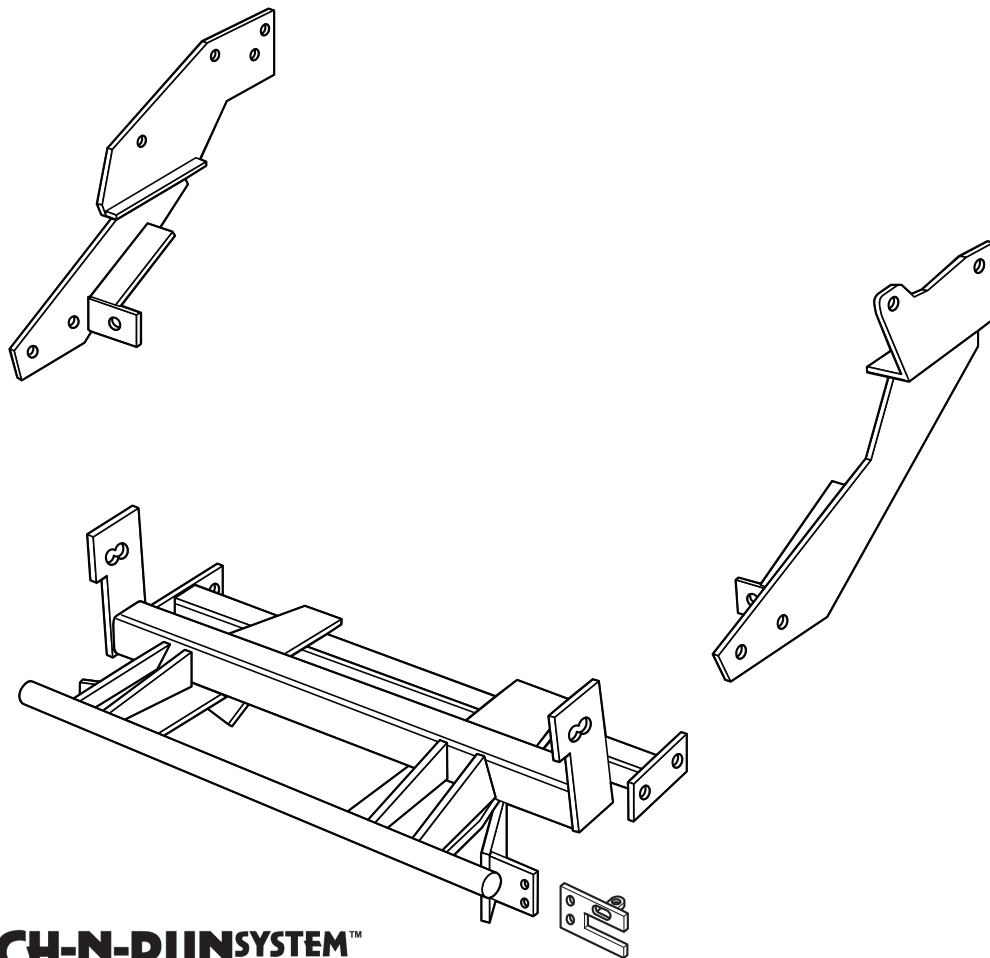

SNO-PRO[®] 3000

1973 - 1986 Chevrolet / GMC K-10 through K-3500
1987 - 1989 Chevrolet / GMC V-1500 through K-3500
1973 - 1991 Crew Cab, Blazer, Jimmy and Suburban Models

Vehicle Mounting Kit: 1FK12



Curtis Industries Inc. LLC, 111 Higgins St., Worcester, MA 01606 TEL: (800) 343-7676 FAX: (508) 854-3377 For Parts and information visit us at www.Curtisindustries.net
Curtis Industries Inc. LLC, reserves the right to change product design or specifications without notice or liability.
Curtis Snow Plows are protected by the following U.S. Patent Numbers: 6,145,222 and 6,209,231 Licensed under U.S. Patent Number 5,568,694 & Canadian Patent Number 2,137,853.
Other patents pending.

1FK12 Vehicle Mount Kit Parts List

Item #	Description	Qty.
1	Mounting Frame	1
2	Driver's Side Push Arm	1
3	Passenger's Side Push Arm Plated	1
Hardware Bag Components Included In This Kit		
4	1/2"-13 x 1-1/2" Bolt, Gr. 5, Cad., Plated	4
5	1/2" Lockwasher, Cad., Plated	4
6	1/2"-13 Hex Nut, Cad., Plated	4
7	5/8"-11 x 2" Bolt, Gr. 5, Cad., Plated	2
8	5/8"-11 x 1-1/2" Bolt Gr. 5, Cad., Plated	5
9	5/8"-11 x 2-1/2" Carriage Bolt, Gr. 5, Cad., Plated	2
10	5/8" Lockwasher, Cad., Plated	9
11	5/8"-11 Hex Jam Nut, Cad., Plated	4
12	5/8" SAE Flat Washer	6
13	5/8"-11 Hex Nut, Cad., Plated	7
14	Spacer	2
Hardware Components Included In Plow Light Harness Kit		
1a	Dual Plug Harness Bracket	1
-	10-32 x 3/4" Hex Head Screw, Plated	2
-	10-32 Nylock Lock Nut, Plated	2
-	8-32 x 1" Hex Head Screw, Plated	1
-	8-32 Nylock Lock Nut, Plated	1
-	#8 Nylon Flat Washer, 3/4" O.D.	1
-	#8 Flat Washer, SAE, Plated	1



WARNING

It is highly recommended that front "helper springs", "airshocks", or other similar devices be installed onto this vehicle to prevent the front suspension from "bottoming out" while carrying a snow plow.

Vehicle must be properly "ballasted" by placing ballast weight behind the centerline of Rear Axle so that no more than 62% of the total weight of the Vehicle, Snow Plow, Driver, Ballast weight, (and any cargo) is placed on the Front Axle while at the same time not exceeding the Gross Vehicle Weight Rating and Front or Rear Gross Axle Weight Ratings.

1FK12 Mounting

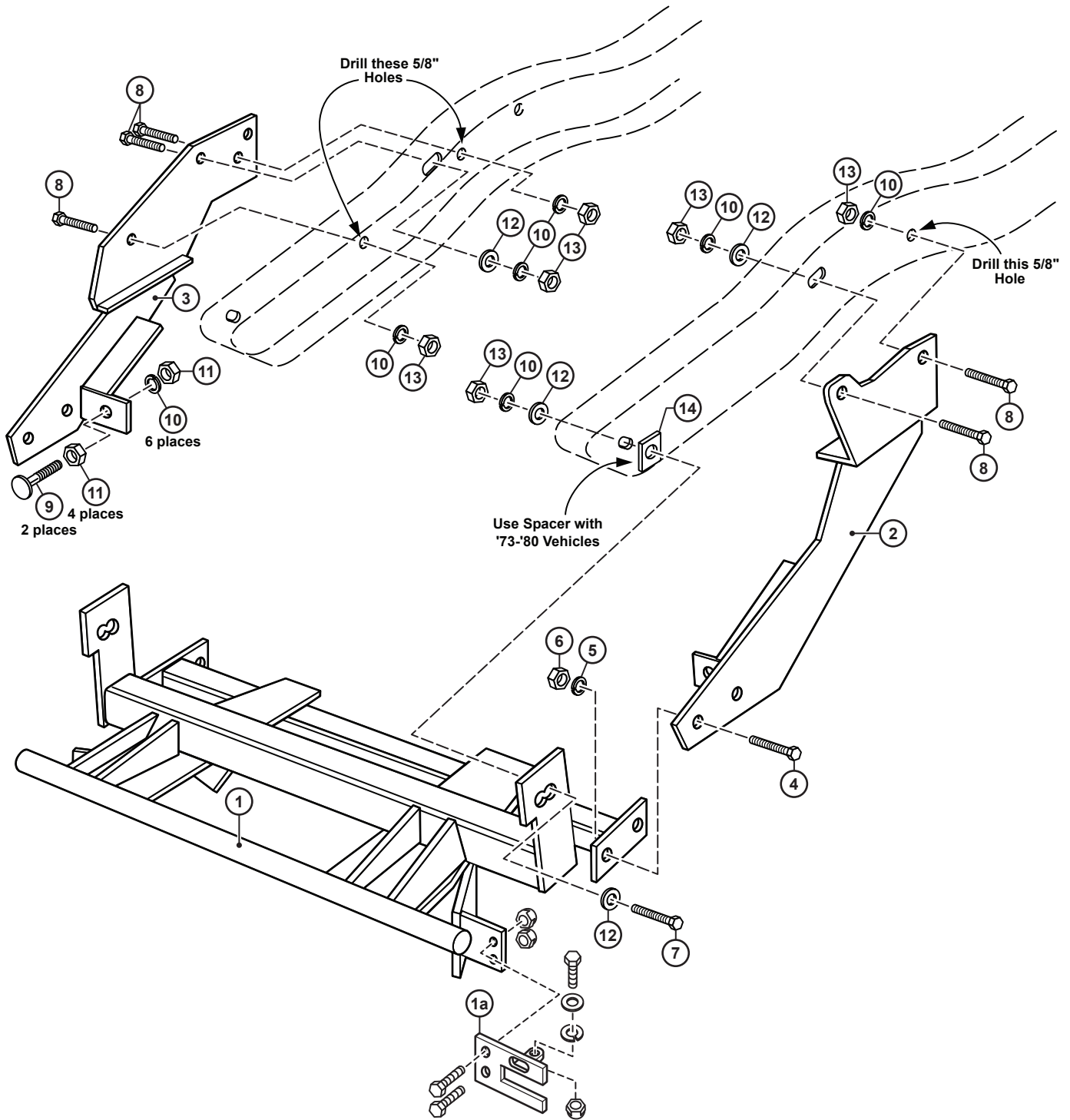

Curtis Industries, LLC. reserves the right to change product design or specifications without notice or liability. Curtis Snow Plows and Truck equipment should only be used on vehicles equipped with the manufacturer's Snow Plow preparation package. Snow Plowing without the original snow plow preparation package may damage your vehicle and the added weight of the equipment may impair the operation and control of the vehicle.

**1FK12: 1973-1986 Chevrolet / GMC K-10 thru K-3500•1987-1989 Chevrolet / GMC V-1500 thru K-3500•
1973-1991 Crew Cab, Blazer, Jimmy and Suburban Models**
Mounting Kit Installation Instructions

1. VEHICLE PREPARATION

- (1a.) If the vehicle has an air dam attached to the front bumper, either trim a 35" long section out of the center of it, or remove it completely. On newer vehicles with separate bumper brackets bolted to the frame rails, remove and discard the lower bumper bracket bolts from each frame rail and drill out the holes to 11/16" diameter. (Older vehicles with the bumper bolted directly to the frame rails do not need this done.)
- (1b.) Jack up the vehicle from under the frame rails until the front tires clear the ground. Place jack stands under the frame to prevent accidental or unintentional lowering of the vehicle.
- (1c.) On the inside of the driver's side frame rail, remove and discard the bolt and clip holding the brake tubing to the frame in the area behind the steering box. Carefully bend the tubing down slightly to clear the slotted hole in the frame rail. On the inside of the passenger's side frame rail, remove and discard the bolt and clip holding the brake tubing to the frame in the area above the front edge of the engine mounting cross member. Carefully bend this tubing up slightly to clear the slotted hole in the frame rail.
- (1d.) Screw a 5/8"-11 hex jam nut (11) all the way onto each of the 5/8"-11 x 2-1/2" carriage bolts (9). Place each carriage bolt/ jam nut assembly into the push ears on the rear push arms (2 & 3) with the heads of the carriage bolts toward the front of the vehicle. Fasten loosely using a 5/8"-11 hex jam nut (11) and 5/8" lock washer (10) on each carriage bolt / jam assembly.



NOTE

All fasteners should remain loose or "finger tight" until all components have been attached to vehicle or installation instructions specify tightening.

2. FRONT MOUNTING FRAME (73 - 80 VEHICLES)

Lift the front mounting frame (1) up onto the vehicle frame with the front vertical mounting ears outside the frame rails and with the front holes in the ears lined up with the slotted holes in the frame rails. Place a spacer (14) between each vertical mounting ear and frame rail. Attach at each frame rail using a 5/8"-11 x 2" bolt (7), two 5/8" flat washers (12), a 5/8" lock washer (10), and a 5/8"-11 hex nut (13).

3. FRONT MOUNTING FRAME (81- VEHICLES)

Lift the front mounting frame (1) up onto the vehicle frame with the front vertical mounting ears outside the frame rails and bumper brackets and with the rear holes in the ears lined up with the previously drilled out lower bumper bracket bolt holes in the frame rails. Attach at each frame rail using a 5/8"-11 x 2" bolt (7), a 5/8" flat washer (12), a 5/8" lock washer (10), and a 5/8"-11 hex nut (13).

4. DRIVER'S SIDE PUSH ARM:

- (4a.) Install the driver's side push arm (2) outside of the vehicle sway bar and inside of the driver's side front leaf spring to the outside of the frame rail. Align the front hole in the rear angle section of the push arm (2) with the existing slotted hole in the in the frame rail. Attach using a 5/8"-11 x 1-1/2" bolt (8), a 5/8" flat washer (12), a 5/8" lock washer (10), and 5/8"-11 hex nut (13).
- (4b.) Align the two holes in the front section of the push arm (2) with the holes in the end plate on the rear cross tube of the mounting frame (1). Attach using 1/2"-13 x 1-1/2" bolts (4), 1/2" lock washers (5), and 1/2"-13 hex nuts (6).

5. PASSENGER'S SIDE PUSH ARM

- (5a.) Install the passenger's side push arm (3) inside of the passenger's side front leaf spring to the outside of the frame rail. Align the middle hole in the rear plate section of the push arm (3) with the existing slotted hole in the frame rail. Attach using a 5/8"-11 x 1-1/2" bolt (8), a 5/8" flat washer (12), a 5/8" lock washer (10), and a 5/8"-11 hex nut (13).
- (5b.) Align the two holes in the front section of the push arm (3) with the holes in the end plate on the rear cross tube of the mounting frame (1). Attach using 1/2"-13 x 1-1/2" bolts (4), 1/2" lock washers (5), and 1/2"-13 hex nuts (6).

6. DRILLING & TIGHTENING

- (6a.) Completely tighten all the fasteners installed up to this point. Using the remaining open hole in the rear angle section of the driver's side push arm (2) as a guide, drill a 5/8" dia. hole through the frame rail. Attach the rear angle section of the push arm (2) at the drilled hole using a 5/8"-11 x 1-1/2" bolt (8), a 5/8" lock washer (10), and a 5/8"-11 hex nut (13).
- (6b.) Using the front open hole and lower rear open hole in the rear plate section of the passenger's side push arm (3) as guides, drill two 5/8" dia. holes through the frame rail. Attach the rear plate section of the push arm (3) at the drilled holes using 5/8"-11 x 1-1/2" bolts (8), 5/8" lock washers (10), and 5/8"-11 hex nuts (13).
- (6c.) Adjust the 5/8"-11 x 2-1/2" carriage bolts (9) with the front 5/8"-11 jam nuts (11) so that the heads of the carriage bolts are tight against the back of the rear cross tube of the front mounting frame (1). Lock the 5/8"-11 x 2-1/2" carriage bolts (9) in place using the rear 5/8"-11 jam nuts (11). Remove Jack stands and lower vehicle to the ground.

7. FINAL ADJUSTMENT AND INSPECTION

Inspect the mounting attachment bolts to be certain that they are all in place and that they are all tight.

8. OPTIONAL PLUG MOUNT BRACKET INSTALL



NOTE

Install the Plug Mount Bracket if the harness will be mounted on the frame kit, otherwise, the harness may be routed through the grill, bumper, etc.

Using (2) 10-32 x 3/4" hex bolts and nylon locknuts, fasten the Plug Mount Bracket to the Plug Mount Bracket Mounting Tab located on the driver's side of the frame kit receiver. The included 8-32 hardware is used for mounting the hi-amp battery leads to the Plug Mount Bracket if used.

