

FLR SERIES

2 TO 15 GHz DIRECT MODULATION MICROWAVE RADIO SYSTEM

MAIN FEATURES

- Advanced, high-performance design meets EIA and CCIR requirements
- Low-noise GaAs FET pre-amplifiers for excellent threshold performance
- Synthesized transmitter and receiver; microwave sources are field-tunable across various frequency bands
- Up to four internal, high-performance program audio channels
- Solid-state FET RF output amplifiers
- Optional high output power versions
- Transmitters and receivers only
3 vertical rack units each
- Modular design
- Configurations include simplex, full duplex, and hot-standby (space or frequency diversity protection)
- Monitor and alarms outputs
- All FCC and CCIR approved bands from 2 to 15 GHz



The FLR Series is advanced design, high-performance, directly modulated microwave equipment suitable for both domestic and international applications, including: STL and TSL, multi-hop and multi-channel broadcast, CATV and ETV video system networks. The equipment can be configured as either a simplex or a duplex system. Protection options, such as hot-standby including space and frequency diversity, are also available.

To provide high system gain, the FLR Series systems incorporate the latest design in field-proven circuitry, such as low-noise receiver pre-amplifiers and high-output, solid-state broadband power amplifiers. A high-power "HP" option is available for additional fade margin protection.

The transmitter and receiver incorporate a microwave RF source that is digitally synthesized, and can be field-switched across entire RF sub-bands. This feature, combined with the broadband RF amplifiers, significantly reduces system sparing requirements, thus minimizing potential downtime. The receiver provides filtered video output, a wideband baseband output, and a standard level 70 MHz IF output.

FLR DIRECT MODULATION MICROWAVE SYSTEM

These compact units (including four internal audio program channels, the optional high-power amplifier, and either AC or DC power supply) only occupy three rack units, thus minimizing the number of racks required for multi-channel systems.

A "D" series connector on the rear of each unit provides access to alarm and monitoring circuits that supply switching signals and data to hot-standby and fault reporting equipment. Hinged front panels allow easy access to all modules and assemblies, including the power supply, for service and maintenance.

All FCC and CCIR approved frequency bands in the 2 GHz to 15 GHz range are supported for domestic and international applications. The Model FLR 12 accommodates A, B, and K channeling plans for 12 GHz CATV applications, and the Model FLR 6 meets 10 MHz channel requirements for 6 GHz private user applications.

FLR TRANSMITTER OPTIONS

High-Power Amplifier: High-power amplifiers are available in many frequency bands. These amplifiers are mounted internally and powered from the standard transmitter power supply. These GaAs FET amplifiers use microstrip transmission line techniques to provide broadband high-power outputs.

Audio Subcarrier Modulators: A 4-channel audio motherboard can be installed as a slide-in board within the FLR chassis. The motherboard can accommodate up to 4 optional audio subcarrier generators. Each generator features a 600 ohm balanced audio input and a selection of subcarrier frequencies at either 75 or 50 microsecond pre-emphasis.

FLR RECEIVER OPTIONS

Audio Subcarrier Demodulators: A 4-channel audio motherboard can be installed as a slide-in board within the receiver chassis. The motherboard can accommodate up to 4 optional audio subcarrier demodulators. Each demodulator features a 600 ohm balanced audio output and a selection of subcarrier frequencies at either 75 or 50 microsecond pre-emphasis.

FLR TRANSMITTER

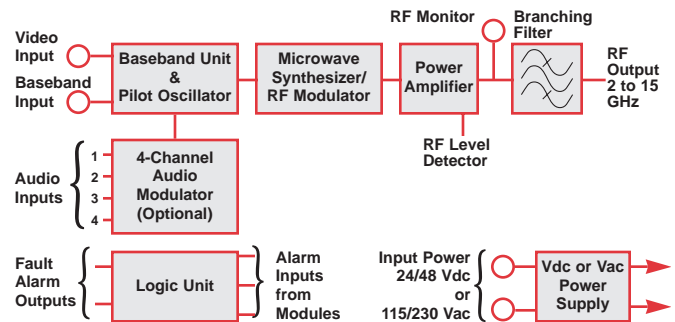

The FLR Series transmitter can be equipped with up to four optional audio modulators within the three-rack unit cabinet.

ACCESSORIES

PAC-10/PAC-12 Audio Subcarrier System: The PAC-10/PAC-12 system inserts additional FM audio subcarriers above the video channel. In addition to transmitting and receiving program audio sources, it can carry telephone channels, engineering orderwire, remote control and alarm signals. Each single-rack unit chassis can accommodate up to four subcarriers.

DigiPro Digital Audio System: The DigiPro System conveys high-quality program material over video microwave radios. The DigiPro Encoder and DigiPro Decoder comprise a digital audio codec (coder/decoder) which converts audio material into a shaped digital signal suitable for transmission over the PAC-10WB wideband subcarrier modulator and PAC-12WB wideband subcarrier demodulator. The

Continued on page 4.

FLR RECEIVER

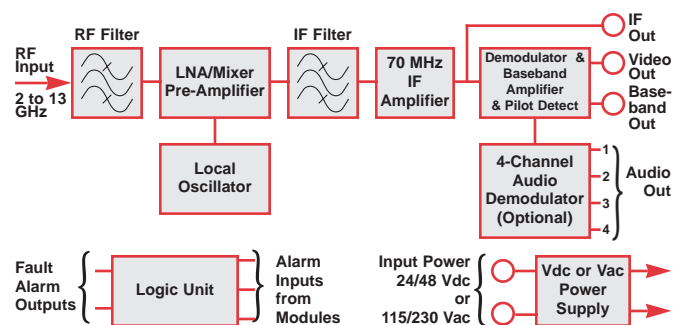

The FLR Series receiver can be equipped with up to four optional audio demodulators within the three-rack unit cabinet.

FLR SPECIFICATIONS

GENERAL

Frequency Bands:	Standard Choices (GHz):
Model FLR 2:	1.9–2.3 or 2.3–2.5
Model FLR 4:	4.4–4.9
Model FLR 6:	5.9–6.4 or 6.4–6.8 or 6.8–7.1
Model FLR 7:	7.1–7.7 or 7.7–8.1 or 8.1–8.5
Model FLR 12:	10.5–12.1 or 12.7–13.2
Model FLR 15:	14.4–15.35
Capacity:	525 or 625 line video, up to 4 audio channels and pilot carrier or video signal plus data above video
Modulation:	FM
Deviation:	± 4 MHz
Baseband Levels:	1 Vp-p, 75 Ω
Frequency Stability (-30° to +50°C):	± 0.005%
Tx Output Power:	(See Operating Specifications Summary)
Rx Noise Figure:	(See Operating Specifications Summary)

VIDEO PERFORMANCE

Frequency Response	
10 kHz to 4.5 MHz (525 line):	± 0.25 dB
10 kHz to 5.0 MHz (625 line):	± 0.25 dB
5 MHz to 8 MHz (Baseband Output):	± 0.50 dB
Field Tilt:	3 IRE max.
Line Tilt:	0.5 IRE max.
Baseband Chroma Delay:	± 20 nS max.
Baseband Chroma Gain:	± 2 IRE max.
Differential Phase:	± 0.2° max.
Differential Gain:	2% max.
Signal-to-Noise Ratio:	Meets or exceeds RS-250C; 67 dB (See Operating Specifications Summary)
Signal-to-Hum (p-p/RMS):	60 dB min.
Video Input Level:	1 Vp-p
Video Input Return Loss:	+ 26 dB min., referenced to 75 Ω

AUDIO PERFORMANCE

Capacity:	Up to four channels included internally
Subcarrier Frequencies:	Standard CCIR or EIA frequency plan
Frequency Response	
40 Hz to 12 kHz:	± 1.0 dB
12 kHz to 15 kHz:	- 1.5 dB max.
Signal-to-Noise Ratio:	Meets or exceeds RS-250C; 66 dB
Distortion:	1% max. at 75 kHz peak deviation
Input Level at Peak Deviation:	0 to +9 dBm adjustable; set + 8 dBm
Output Level:	0 to +9 dBm adjustable; set + 8 dBm
Input Impedance:	600 Ω balanced
Output Impedance:	600 Ω balanced standard; less than 30 Ω optional

Note: all measurements made in accordance with EIA specifications or CCIR recommendations, unless noted.

OPERATING SPECIFICATIONS SUMMARY

Model	Frequency Range (GHz)	TX Output Power ¹ (dBm)	RX Noise Figure ² (dB)	RX Thresh- hold ³ (dBm)	System Gain ² (dB)	Typical Signal/ Noise ³ (dB)
FLR 2	1.7–2.7	+ 37	2.5	- 86	123	75
FLR 4	4.4–4.9	+ 33	3.5	- 85	118	73
FLR 6	5.9–7.1	+ 33	3.5	- 85	118	73
FLR 6HP	5.9–7.1	+ 37	3.5	- 85	122	73
FLR 7	7.1–8.5	+ 30	3.5	- 85	115	70
FLR 7HP	7.1–8.5	+ 34	3.5	- 85	119	70
FLR 12	10.5–13.2	+ 30	4.0	- 84	114	70
FLR 12HP	10.5–13.2	+ 33	4.0	- 84	117	70
FLR 15	14.4–15.35	+ 30	4.0	- 84	114	70

Notes: "HP" suffix indicates high power option

¹ Minimum power to branching network

² Does not include branching filter

³ For one-hop, NTSC video; EIA/CCIR weighting

PRIMARY POWER

AC Power:	115/230 Vac, 50/60 Hz
DC Power:	20.5 to 29 Vdc or 40 to 56 Vdc
FLR 2 Transmitter:	90 Watts
FLR 4 – 15 Transmitters:	80 Watts; HP versions: 90 Watts
All Receivers:	60 Watts

ENVIRONMENTAL

Operating Temperature Range:	0° to + 40°C
Relative Humidity:	0 to 95%, non-condensing

PHYSICAL

Height (Mounting Requirements)	
Transmitter/Receiver:	3 rack units: 5 1/4" (13.34 cm)
Depth	
Without Waveguide:	15.0" (38.1 cm)
With Waveguide:	19.5" (49.53 cm)
Repeater Waveguide and Hot-Standby Receiver:	21.5" (54.61 cm)
Hot-Standby Transmitter:	22.25" (56.51 cm)
Weight:	Approximately 20 lbs (9 kg)

INTERCONNECTION

RF Connections	
1.71 to 4.90 GHz:	Type "N" female connector
5.925 to 7.125 GHz:	Type WR137; CPR @ top of rack
7.10 to 8.50 GHz:	Type WR112; CPR @ top of rack
10.70 to 13.25 GHz:	Type WR75
14.4 to 15.35 GHz:	Type WR62
IF/Baseband Connectors:	BNC
Power, Audio, and Alarm Connections:	Barrier strip, screw terminals

FLR DIRECT MODULATION MICROWAVE SYSTEM

Continued from page 2.

complete DigiPro System is supplied with the Encoder, Decoder, PAC-10WB and PAC-12WB; it can be configured for two program audio channels or one stereo channel and one data channel.

SC-1 Service Channel Converter: The SC-1 service channel converter inserts a single sideband suppressed carrier subcarrier above the video channel. This capability allows the user to multiplex engineering orderwire, alarm and status monitoring with up to 24 FDM telephony channels.

HS-1 Hot-Standby Protection System: The HS-1 Hot-Standby Switching System provides complete redundancy for the system. It is composed of two

one-rack unit shelves, one transmit and one receive.

OTHER ACCESSORIES

MRC also offers other protection schemes such as baseband and IF space diversity with the DS-1 and DS-2 diversity switches. The PS-1 1+N switch protects up to 11 channels with a standby channel. The PS-1 is available in single video with up to four audio channel protection.

FOR MORE INFORMATION

For more information about the FLR Series, please call your local MRC representative, or contact MRC directly.

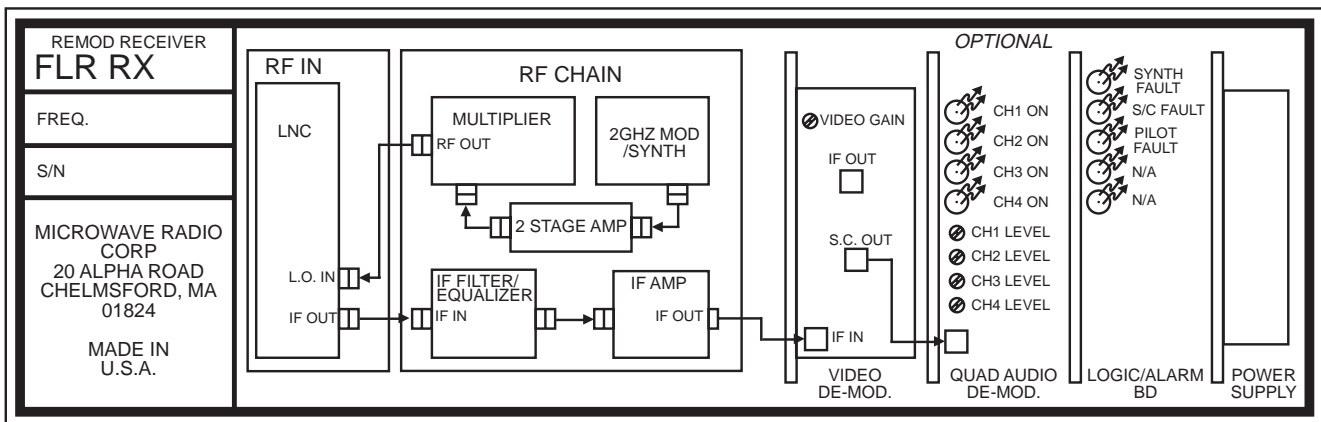
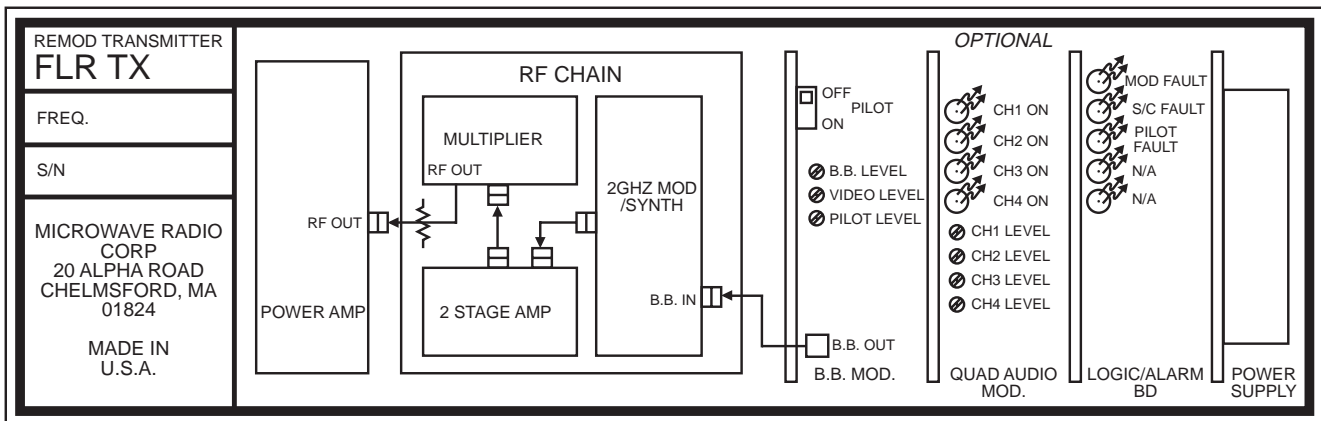

With the FLR Series radios, all modules are easy to reach from the fold-down front door. Up to four audio subcarriers fit within the standard three rack unit chassis.



**MICROWAVE
RADIO
COMMUNICATIONS**



Microwave Radio Communications
20 Alpha Road
Chelmsford, MA 01824-4168 USA

Tel, U.S. & Canada: (800) 490-5700
Telephone: (978) 250-1110
Facsimile: (978) 256-6225

E-mail: sales@cm-mrc.com
Internet: http://www.cm-mrc.com

All specifications subject to change without notice. Part#: 52500-49
© 1998 Microwave Radio Communications Printed in U.S.A. 3/98